

SVT series

Built in bypass type intelligent motor
soft starter/cabinet

Operating Instructions



Chapter 1 Cautionary Statement



This symbol is used in this manual to remind readers to attach great importance to special precautions concerning equipment installation and operation.

The caution statement cannot cover every possible cause of equipment damage, but it can emphasize common causes of damage. The installer must read and understand all the instructions in this manual before installing, operating or maintaining the equipment, and must follow effective electrical installation practices (including wearing appropriate personal protective equipment), such as using a method different from that described in this manual. To operate the equipment, advice must be sought in advance.



pay attention to

The user cannot repair the soft start. The soft start can only be serviced by authorized service personnel. Unauthorized modification of the soft starter will invalidate the product warranty.

1.1 Risk of electric shock

There is voltage at the following positions, which may cause serious electric shock accidents and can be fatal:

- AC power cord and connection
- Output wires and connections
- Many components of starters and external optional equipment

Before opening the starter cover or performing any maintenance work, the AC power supply must be isolated from the starter with an approved isolating device.



Warning-risk of electric shock

As long as the supply voltage is connected (including when the starter is tripped or waiting for a command), the bus and the heat sink must be considered live.



Short circuit

Cannot prevent short circuit. After a severe overload or short circuit occurs, an authorized service agent should fully test the soft start working conditions.



Grounding and branch circuit protection

The user or installer must provide proper grounding and branch circuit protection in accordance with the requirements of local electrical safety regulations.



For safety

- The stop function of the soft start does not isolate the dangerous voltage at the output of the starter. Before touching the electrical connection, the soft starter must be disconnected with an approved electrical isolation device.
- The soft start protection function is only applicable to motor protection. The user must ensure the safety of machine operators.
- In some installation situations, accidental starting of the machine may endanger the safety of machine operators and may damage the machine. In such cases, it is recommended that you install an isolating switch and circuit breaker (such as a power contractor) that can be controlled by an external safety system (such as emergency stop and fault detection period) on the soft starter power supply.
- The soft starter has a built-in protection mechanism, and the starter trips when a fault occurs to stop the motor. Voltage fluctuations, power outages and motor jams can also cause the motor to trip.
- After eliminating the cause of the shutdown, the motor may restart, which may endanger the safety of some machines or equipment. In this case, proper configuration must be made to prevent the motor from restarting after an unexpected shutdown.
- The soft start is a well-designed component that can be integrated into the electrical system; the system designer/user must ensure that the electrical system is safe and meets the requirements of the corresponding local safety standards.
- If you do not comply with the above recommendations, our company will not bear any responsibility for any damage caused thereby.

1.2 Appearance and installation dimensions of the built-in bypass intelligent motor soft starter:

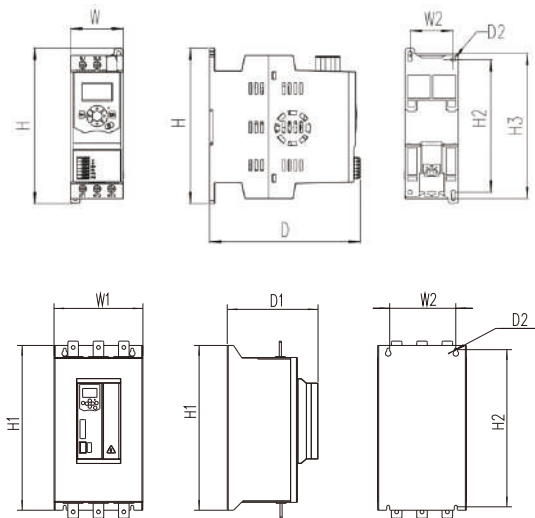

Specification model	Dimensions (mm)			Installation size (mm)			
	W1	H1	D	W2	H2	H3	D2
0.37-15KW	55	162	157	45	138	151.5	M4
18-37KW	105	250	160	80	236		M6
45-75KW	136	300	180	95	281		M6
90-115KW	210.5	390	215	156.5	372		M6

1.2.1 Dimensions and specifications

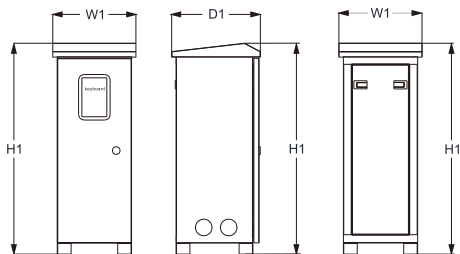

Specification and model	Dimensions (mm)		
	W1	H1	D1
0.37-15KW	210	440	200
18.5-37KW	300	760	320
45-75KW	320	830	330
90-115KW	330	1100	370

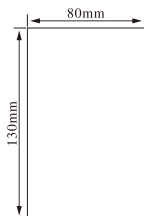

Installation size of external keyboard (mm)

Chapter 2 Introduction

This soft starter is an advanced digital soft start solution suitable for motors with power ranging from 0.37kW to 115k. Provides a complete set of comprehensive motor and system protection functions, ensuring reliable performance even in the harshest installation environments.

2.1 Function list

Optional soft start curve

- Voltage ramp start
- Current Limit Start

Optional soft stop curve

- Free parking
- Timed soft parking

Expanded input and output options

- Remote control input
- Relay output
- RS485 communication output

Easy to read display with comprehensive feedback

- Removable operation panel
- Built-in Chinese + English display

Customizable protection

- Input phase loss
- Output phase loss
- Running overload
- Starting overcurrent
- Running overcurrent
- Underload

Models that meet all connectivity requirements

- 0.37-115KW (rated)
- 220VAC-380VAC
- Star shaped connection or inner triangle connection

Chapter 2 Instructions for External Terminals of Built in Bypass Intelligent Motor Soft Start

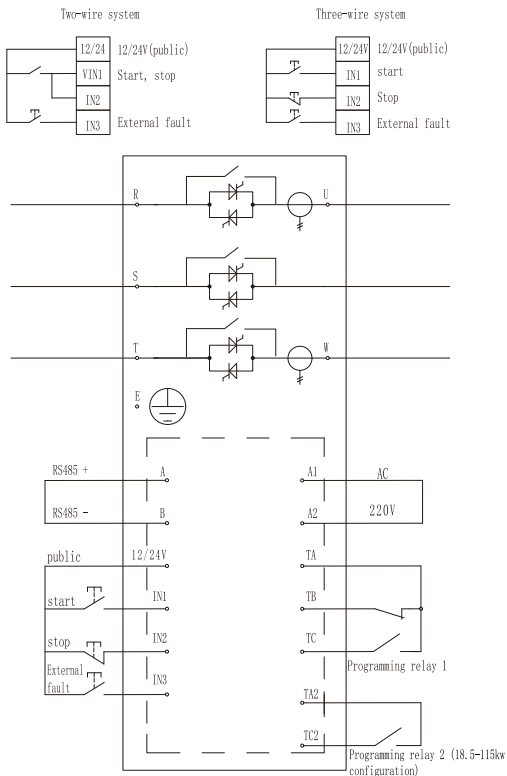

Built In Bypass Soft Starter/Cabinet

Terminal type		Terminal No.	Terminal name	Instruction
Main circuit		R,S,T	Power Input	Soft start three-phase AC power input
		U,V,W	Soft Start Output	Connect three-phase asynchronous motor
Control loop	Communication	A	RS485+	For ModBusRTU communication
		B	RS485-	
	Digital input	12V	Public	12/24V common
		IN1	start	Short connection with common terminal (12/24V) Startable soft start
		IN2	Stop	Disconnect from the common terminal (12/24V) to stop the start soft start
		IN3	External Fault	Short-circuit with the common terminal (12/24V) , soft start and shutdown
	Soft start power supply	A1	AC220V	220V
		A2		
	Programming Relay 1	TA	Programming relay common	Programmable output, available from Choose from the following functions: 0. No action 1. Power-on action 2. Soft start action 3. Bypass action 4. Soft stop action 5. Runtime actions 6. Standby action 7. Failure action
		TB	Programming relay normally closed	
		TC	Programming relay normally open	
	Programming relay 2 18.5-115kw (Configuration)	TA2	Programming relay normally open	
TC2				

Chapter 3 Operation Panel

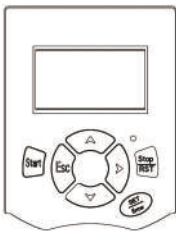

key	function
Start	starter
STOP/RST	<ol style="list-style-type: none"> 1. In case of fault tripping, reset 2. Stop the motor while starting it
ESC	Exit menu/submenu
▲	<ol style="list-style-type: none"> 1. In the starting state, the up key will call out the display interface for the current values of each phase 2. Move option up in menu state
▼	<ol style="list-style-type: none"> 1. Display interface for each phase current value, move down key to turn off each phase current display 2. Move option up in menu state
➡➡	<ol style="list-style-type: none"> 1. In menu mode, the displacement key moves the menudown by 10 items 2. In the submenu state, the displacement key moves the menu selection bit to the right in sequence 3. Long press and hold the displacement in standby mode to call out the factory reset and clear the fault record interface
SET/Enter	<ol style="list-style-type: none"> 1. Call out menu during standby 2. Enter the next level menu within the main menu 3. Confirm adjustments
Fault light	<ol style="list-style-type: none"> 1. Lights up when starting/running the motor 2. Flashing during malfunction

Starter status LED

name	Light	flicker
run	The motor is in a starting, running, soft stop, and DC braking state.	
tripping operation		The starter is in a warning/tripping state

● The local LED light only works for keyboard control mode. When the light is on, it indicates that the panel can start and stop. When the light is off, the meter The display panel cannot be started or stopped.

Chapter 4 Basic Parameters

function			
number	function name	set range	Default value
F00	Soft start rated current	Soft start rated current	
F01	Motor rated current	Motor rated current	
F02	control mode	0: Prohibit start stop 1: Individual keyboard control 2: External control is individually controlled 3: Keyboard+external control 4: Separate communication control 5: Keyboard+Communication 6: External control+ communication 7: Keyboard+external control +communication	3: Keyboard +external control
F03	Starting method 000000	0: Voltage ramp start 1: Limited current starting	0: Voltage ramp start
F04	Starting current limiting percentage	50%~600%	300%
F05	Starting voltage percentage	30%~80%	35%
F06	START time	1s~120s	15s
F07	Soft stop time	0s~60s	0s
F08	Programmable relay 1	0: No action 1: Power on action 2: Soft start middle action 3: Bypass action 4: Soft stop action 5: Running actions 6: Standby action 7: Fault action	7: Fault action
F09	Relay 1 delay	0~600s	0s
F10	Programmable relay 2 (18.5-115kw available)	0: No action 1: Power on action 2: Soft start middle action 3: Bypass action 4: Soft stop action 5: Running actions 6: Standby action 7: Fault action	3: Bypass action
F11	Relay 2 delay	0~600s	0s
F12	mail address	1~127	1
F13	Baud rate	0:2400 1:4800 2:9600 3:19200	2:9600
F14	Operating overload level	1~30	10
F15	Starting overcurrent multiple	50%-600%	500%
F16	Start overcurrent protection time	0s-120s	5s

Built In Bypass Soft Starter/Cabinet

number	function name	set range	Default value
F17	Operating overcurrent multiple	50%-600%	200%
F18	Running overcurrent protection time	0s-6000s	5s
F19	Three-phase unbalance	20%~100%	40%
F20	Three phase imbalance protection time	0s~120s	10s
F21	Underload protection multiple	10%~100%	50%
F22	Underload protection time	1s~300s	10s
F23	A-phase current calibration value	10%~1000%	100%
F24	B-phase current calibration value	10%~1000%	100%
F25	C-phase current calibration value	10%~1000%	100%
F26	Voltage calibration value	10%~1000%	100%
F27	Operation overload protection	0: Trip stop 1: Ignored	0: Trip stop
F28	Starting overcurrent protection	0: Trip stop 1: Ignored	0: Trip stop
F29	Operation overcurrent protection	0: Trip stop 1: Ignored	0: Trip stop
F30	Unbalance protection	0: Trip stop 1: Ignored	0: Trip stop
F31	Underload protection	0: Trip stop 1: Ignored	1: Ignored
F32	Input phase loss protection	0: Trip stop 1: Ignored	1: Ignored
F33	Output phase loss protection	0: Trip stop 1: Ignored	0: Trip stop
F34	Thyristor breakdown protection	0: Trip stop 1: Ignored	0: Trip stop
F35	Soft start operation language	0: English 1: Chinese	1: Chinese
F36	Selection of water pump matching equipment	0: None 1: Floating ball 2: Electric contact pressure gauge 3: Water supply level relay 4: Drainage liquid level relay	0: None
F37	Running a Simulation		
F38	Terminal reset	0: Valid 1: Invalid	0: Valid
F39	Parameter lock password	00000-99999	0
F40	Accumulated running time		
F41	Accumulated number of starts		
F42	Manufacturer parameters		
F43	Automatic reset time	0-3600s 0 indicates no automatic reset	0s
F44	Main control software version number		

Built In Bypass Soft Starter/Cabinet

Selection of supporting functions for water pumps

①	0: None	No: Standard soft start function.	As shown in Figure 1
②	1: Floating ball	Float: IN1, close to start, open to stop. IN2 has no function.	As shown in Figure 2
③	2: Electric contact pressure gauge	Electric contact pressure gauge: IN1 starts when closed, IN2 stops when closed.	As shown in Figure 3
④	3: Water supply level relay	Water supply level relay: IN1 and IN2 both open and start, IN1 and IN2 both close and stop.	As shown in Figure 4
⑤	4: Drainage liquid level relay	Drain liquid level relay: IN1 and IN2 both open and stop, IN1 and IN2 both close and start.	As shown in Figure 5

Note: The water supply function starts and stops controlled by IN3, the standard soft start IN3 is an external fault, and the water supply type is used to control the start and stop, IN3 is the starting end, and the above operation can be performed only when it is closed, and it stops when it is open.

0: None



figure 1

1: Float

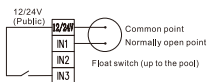

Soft start, stop figure 2

2: Electric contact pressure gauge

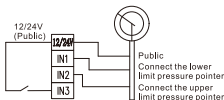

Soft start, stop figure 3

3: Water supply level relay

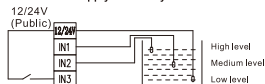

Soft start, stop

4: Drain level relay

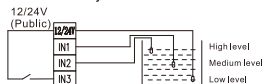

Soft start, stop

Chapter 5 Parameter Description

F01. Control method

Range: 0-6

Default value: 3

Explanation: Set the control method for selecting the soft starter

Attached is a table, where V represents start stop capability and x represents non start stop capability

numerical value	0	1	2	3	4	5	6
keyboard	x	√	x	√	x	√	√
terminal	x	x	√	√	x	x	√
communication	x	x	x	x	√	√	√

F03. Starting method

Option 0: Voltage ramp start (default)

1: Current limiting start instructions: Select soft start method

F04. Starting current limiting percentage

Range: 50% -600% rated current

Default value: 300%

Explanation: Set the maximum starting current for soft start during current limiting starting, which is the percentage of the rated current of the motor

F05. Starting voltage percentage

Option: 20% -80%

Explanation: Set the initial starting voltage value for voltage starting and current limiting starting. In closed-loop mode, the minimum starting voltage is 37%. If it is set below 37%, start at 37%, and if it is greater than or equal to 37%, start at the set value

F06. Start time

Scope: 1S-120S

Default value: 15S

Explanation: Set the total starting time for soft start during voltage starting

F07. Soft stop time

Scope: 1S-60S

Default value: 0S

Explanation: Set a timed voltage ramp to soft stop the motor for a certain amount of time. After the soft stop, the motor will automatically slide until it stops

F08. Programmable Relay 1

Option:

0: No action, no use of relay A.

1: When the soft starter is powered on, the relay will activate.

2: When the soft starter is in the soft start state, the relay will activate.

3: The bypass action soft starter switches to the running state after starting is completed, and the relay acts.

4: In the soft stop state, the soft starter will activate the relay.

5: When the soft starter is in an output state, the relay will activate.

6: In standby mode, the soft starter will activate the relay.

7: Fault action (default) When the soft starter is in a fault state, the relay will activate.

Built In Bypass Soft Starter/Cabinet

F09. Relay 1 delay

Range: 0s-600s

Default value: 0s

Explanation: Set the action delay of programmable relay 1, set it to 0 to indicate immediate action without delay

F10. Programmable Relay 1

Option:

0: No action, no use of relay A.

1: When the soft starter is powered on, the relay will activate.

2: When the soft starter is in the soft start state, the relay will activate.

3: The bypass action soft starter switches to the running state after starting is completed, and the relay acts.

4: In the soft stop state, the soft starter will activate the relay.

5: When the soft starter is in an output state, the relay will activate.

6: In standby mode, the soft starter will activate the relay.

7: Fault action (default) When the soft starter is in a fault state, the relay will activate.

F11. Relay 2 delay (18.5-115kw can be used)

Range: 0s-600s

Default value: 0s

Explanation: Set the action delay of programmable relay 1, set it to 0 to indicate immediate action without delay

F12. Communication address

Range: 1-127

Default value: 1

Explanation: Used for communication between multiple soft starters and upper computers.

F13. Communication Baud Rate

option: 0: 2400 1: 4800 2: 9600(default) 3: 19200

Explanation: Select the data transmission rate in communication mode.

F14. Operating overload level

Range: 1-30

Default value: 10

Explanation: The operation overload protection adopts inverse time limit control, and the protection time corresponding to different levels refers to the motor overload protection characteristic table or F17 and F18 parameters according to the first arrival time protection.

F15. Starting overcurrent multiple

Range: 50% -600% rated current

Default value: 500%

Explanation: Set the instantaneous overcurrent protection trip point for soft starting, which is the percentage of the rated motor current.

F16. Start overcurrent protection time

Range: 0S-120S

Default value: 5S

Explanation: Set the response speed of soft starting to starting overcurrent to reduce tripping caused by instantaneous fluctuations

F17. Running overcurrent signals

Range: 50% -600% rated current

Default value: 200%

Explanation: Set the operating overcurrent protection trip point for soft start during operation as a percentage of the rated motor current.

Built In Bypass Soft Starter/Cabinet

F18. Running overcurrent protection time

Range: 0S-6000s

Default value: 5s

Explanation: Set the response speed of soft start to operating overcurrent to reduce tripping caused by instantaneous fluctuations.

F19. Three phase imbalance

Range: 20%-100%

Default value: 40%

Explanation: Set the protection trip value for three-phase imbalance in soft start, and the difference between phases is greater than the set value Value is protected.

F20. Three phase imbalance protection time

Range: 1S-600S

Default value: 3S

Explanation: Set to reduce the response speed of soft start to three-phase imbalance, to avoid tripping due to instantaneous fluctuations.

F21. Underload protection multiple

Range: 1S-120S

Default value: 50%

Explanation: Set the undercurrent protection trip point for soft start during operation, which is the percentage of the motor's rated current.

F22. Underload protection time

Range: 10%-100%

Default value: 10S

Explanation: Set to reduce the response speed of soft start to under current, avoiding tripping due to instantaneous fluctuations,

F23. A-phase current calibration value

Range: 10%-1000%

Default value: 100%

Explanation: Calibrate the A-phase current monitoring circuit of the soft starter to match with external current measurement equipment
Determine the necessary adjustment amount using the following formula:
Calibration (%)=Soft start external device measurement current/Display current displayed on the display, for example 102%=51A/50A

Note: This adjustment affects all current based functions and protection.

F24. B-phase current calibration value

Range: 10%-1000%

Default value: 100%

Explanation: Calibrate the B-phase current monitoring circuit of the soft starter to match with external current measurement equipment
Determine the necessary adjustment amount using the following formula:
Calibration (%)=Soft start external device measurement current/Display current displayed on the display, for example 102%=51A/50A

Note: This adjustment affects all current based functions and protection.

F25. C-phase current calibration value

Range: 10%-1000%

Default value: 100%

Explanation: Calibrate the C-phase current monitoring circuit of the soft starter to match with external current measurement equipment
Determine the necessary adjustment amount using the following formula:
Calibration (%)=Soft start external device measurement current/Display current displayed on the display, for example 102%=51A/50A

Note: This adjustment affects all current based functions and protection.

Built In Bypass Soft Starter/Cabinet

F26. Voltage calibration value

Range: 10% -1000%

Default value: 100%

Explanation: Calibrate the input voltage monitoring circuit of the soft starter to match with external voltage measurement equipment

Determine the necessary adjustment amount using the following formula:

Calibration (%)=Soft start external device measurement voltage/Display display voltage, for example 102%=387.6V/380V

F27. Operation overload protection

Scope: 0: Trip stop

Default value: 0: Trip stop

1: Ignoring

F28. Starting overcurrent protection

Scope: 0: Trip stop

Default value: 0: Trip stop

1: Ignoring

F29. Operation overcurrent protection

Scope: 0: Trip stop

Default value: 0: Trip stop

1: Ignoring

F30. Three phase imbalance protection

Scope: 0: Trip stop

Default value: 0: Trip stop

1: Ignoring

F31. Underload protection

Scope: 0: Trip stop

1: Ignoring

1: Ignoring

F32. Input phase loss protection

Scope: 0: Trip stop

1: Ignoring

1: Ignoring

F33. Output phase loss protection

Scope: 0: Trip stop

1: Ignoring

1: Ignoring

F34. Thyristor breakdown protection

Scope: 0: Trip stop

1: Ignoring

1: Ignoring

F35. Soft Start Operation Language

Option: 0: English 1: Chinese (default)

Explanation: Select the language for displaying messages and feedback on the operation panel.

F36. Selection of water pump matching

Range: 0: None

Default value: None

1: Floating ball

2: Electric contact pressure gauge

3: Water supply level relay

4: Drainage liquid level relay

Explanation: Select the corresponding function based on the on-site control model

Chapter 6 Troubleshooting

6.1 Protection response

When a protection condition is detected, the soft start writes the protection condition into the program, which may trip or cause Issue a warning. The soft start response depends on the protection level.

Users cannot adjust some of the protection responses. These trips are usually caused by external events (such as phase loss) It may also be caused by internal faults in the soft start. These trips have no relevant parameters and cannot be set as warnings or ignored.

If The Soft Start Trips, You Need To Identify And Clear The Conditions That Triggered The Trip, Reset The Soft Start, And Then Proceed Restart. To Reset The Starter, Press The (stop/reset) Button On The Control Panel.

6.2 Trip messages

The following table lists the protection mechanisms and possible tripping reasons for soft start. Some settings can be adjusted with protection level , while others are built-in system protection and cannot be set or adjusted.

Serial Number	Fault name	Possible reasons	Suggested handling method	notes
01	Input phase loss	1. Send a start command , and one or more phases of the soft start are not powered on. 2. The motherboard of the circuit board is faulty.	1. Check if there is power in the main circuit 2. Check the input circuit thyristor for open circuits, pulse signal lines, and poor contact. 3. Seek help from the manufacturer.	Related parameters: F32
02	Output phase loss	1. Check if the thyristor is short circuited. 2. There is one or more phases of open circuit in the motor wire. 3. The motherboard of the circuit board is faulty.	1. Check if the thyristor is short circuited. 2. Check if the motor wires are open. 3. Seek help from the manufacturer.	Related parameters : F33
03	Running overload	1. The load is too heavy. 2. Improper parameter settings.	1. Replace with a higher power soft start. 2. Adjust parameters.	Related parameters : F14, F27

Built In Bypass Soft Starter/Cabinet

Serial Number	Fault name	Possible reasons	Suggested handling method	notes
04	Underload	1. The load is too small. 2. Improper parameter settings.	1. Adjust parameters.	Related parameters: F21,F22,F31
05	Running overcurrent	1. The load is too heavy. 2. Improper parameter settings.	1. Replace with a higherpower soft start. 2. Adjust parameters.	Related parameters: F17,F18,F29
06	Starting overcurrent	1. The load is too heavy. 2. Improper parameter settings.	1. Replace with a higherpower soft start. 2. Adjust parameters.	Related parameters: F15,F16,F28
07	External faults	1. External fault terminalhas input.	1. Check if there is input from the externalterminals.	Related parameters : None
08	Thyristor breakdown	1. The thyristor has broken down. 2. Circuit board malfunction.	1. Check if the thyristor is broken down. 2. Seek help from the manufacturer.	Related parameters : F34
09	Start timeout	1. Insufficient power capacity 2. The load is too heavy 3. Improper parameter settings	1. Adjust parameters	Related parameters: F03,F06

Chapter 7 Function Description

Overload protection

Overload protection adopts inverse time limit control

$$\text{Protection time: } t = \frac{35 \cdot T_p}{(I/I_p)^2 - 1}$$

Among them: t represents the action time, T_p represents the protection level, I represents the operating current, and I_p represents the rated current of the motor
 Characteristic curve of motor overload protection: Figure 11-1

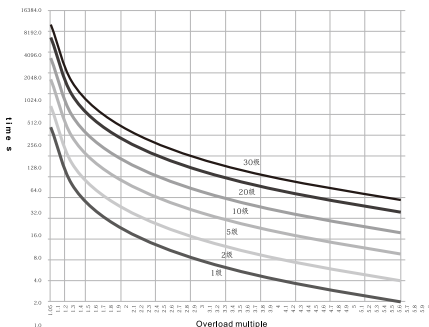

Motor overload protection characteristics

overload multiple \ overload level	1.05I _e	1.2I _e	1.5I _e	2I _e	3I _e	4I _e	5I _e	6I _e
1	∞	79.5s	28s	11.7s	4.4s	2.3s	1.5s	1s
2	∞	159s	56s	23.3s	8.8s	4.7s	2.9s	2s
5	∞	398s	140s	58.3s	22s	11.7s	7.3s	5s
10	∞	795.5s	280s	117s	43.8s	23.3s	14.6s	10s
20	∞	1591s	560s	233s	87.5s	46.7s	29.2s	20s
30	∞	2386s	840s	350s	131s	70s	43.8s	30s

∞: Indicates no action

Chapter 8 Modbus Communication Protocol

Communication protocol

8.1 Overview of Modbus RTU Communication Protocol

This series of soft start provides RS485 communication interface and supports Modbus RTU slave communication protocol. Users can achieve centralized control through calculation or implementation

Electrical interface: RS485 half duplex

Communication parameters: baud rate 9600, 8-bit data bit, no checksum bit, 1 bit stop bit; Communication data format

Data format:	Address code	Function code	Data area	CRC verification
Data length:	1 byte	1 byte	N byte	2 byte

Soft starter related settings

8.2.1 Supporting Code

The soft starter only supports the following codes. If other codes are used, an exception code will be provided

code	03	06
Functional Description	Read Register	Write a single register

Code 03 can only be read with a single word (WORD)

Function Name	Function options	Modbus address
Soft start state	0: standby 1: Soft rise 2: Running 3: Soft stop 5: Fault	100
Current fault	0: No malfunction 1: Input phase loss 2: Output phase loss 3: Running overload 4: Running overcurrent 5: Starting overcurrent 6: Soft start under load 7: Current imbalance 8: External faults 9: Thyristor breakdown 10: Start timeout 11: Internal fault 12: Unknown fault	101

Output current		102
input voltage		103
A-phase current		104
B-phase current		105
C-phase current		106
Start completion percentage		107
Three-phase imbalance		108
Power frequency		109
Power phase sequence		110
Reset Countdown		111

Soft start fault reading:

Record Name		Modbus address
First fault record		300
Second fault record		301
Third fault record		302
Fourth fault record		303
Fifth fault record		304
Sixth fault record		305
Seventh fault record		306
Eighth fault record		307
Ninth fault record		308
Tenth fault record		309
Eleventh fault record		310
Twelfth fault record		311

Soft start operation command reading:

Operation Name	Function options	Modbus address
Start stop command	0x0001 Start 0x0002 reserved 0x0003 Stop 0x0004 Fault reset	406

8.3 Abnormal Response

code	name	explain
01	Illegal function	Function code soft starter not supported
02	Illegal data address	Illegal address, unable to execute
03	Illegal data value	The received data cannot be executed 1: Parameter exceeds space 2: Parameters cannot be modified 3: At runtime, parameters cannot be modified



pay attention to:

- The communication address, communication rate, and verification mode of the soft starter must be the same as the communication settings of the controller
- If no response data is received, check the parameter settings above and ensure that the terminal connections are correct.
- When communicating with multiple soft starters, a 120 ohm resistor should be connected at both ends of the last 485+ and 485- terminals.
- When connecting to other MODEBUS devices, follow the following diagram:

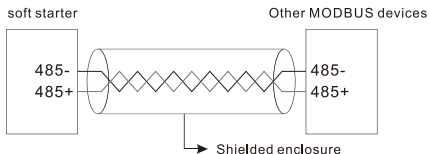

NIETZ ELECTRIC CO.,LTD

No.988, Fulian Rd. Gucun
Industry, Baoshan District.
Shanghai, China

Tel/ Fax: +86 21 336 346 49
E-mail: info@nietz.cn
Website: www.nietz.cn



DISTRIBUTORS