

INDUSTRIAL DISC BRAKES



PRODUCT BROCHURE

ADVANCED BR AKING TECHNOLOGY

i n t r o d u c t i o n

Twiflex Limited, with headquarters in Twickenham, England, specialise in the design, manufacture and supply of Advanced Braking Technology for Industrial Applications. With extensive in-house design, engineering, manufacturing and assembly facilities, Twiflex have a well-deserved reputation for quality and precision.

Founded in 1946, Twiflex have supplied approximately 500,000 brakes, frequently for critical applications, around the World. From textile machines in Bolton to the World's deepest mine shaft in South Africa, Twiflex brakes enjoy a premier status amongst Engineers and Operators in every type of Industry.

Although an approximate selection can be made by assessing the data contained within this brochure, it is always wise to contact a Twiflex agent directly for a more detailed proposal.

Whether you are looking to purchase the most advanced braking system in the World or simply component parts, we hope this brochure will serve as a useful guide.

c o n t e n t s

1	APPLICATIONS	2
2	BRAKE SYSTEM OVERVIEW	4
3	BRAKE CALIPER RANGE	
	MU Series	6
	MS Series	8
	MR Series	11
	MX Series	15
	GMX Series	20
	GMR Series	25
	Modular Series	28
4	DISC AND HUB ASSEMBLIES	35
5	PNEUMATIC CONTROLLERS	36
6	INTENSIFIERS	37
7	MONITOR UNITS	38
8	HYDRAULIC POWER UNITS	39
9	BRAKING CALCULATIONS	40



Conveyors

Disc brakes are used on conveyors for four main reasons:

- An emergency stop
- For normal stopping and parking
- Where one conveyor feeds another and there is a risk of over spill
- Wherever there exists a risk of personal injury particularly under ground

The brakes may be fitted to the tail drum, driving drum or motor shaft, but with long over ground conveyors, Twiflex recommend that the brake is fitted to the up stream end to prevent a catapult effect due to reversal of belt tension.

Twiflex has developed brake controllers ranging from simple on/off to the more sophisticated systems that interface with drive motor and speed sensors to provide specific starting and stopping profiles.



Wind turbines

Twiflex disc brakes can be used on wind energy generators on both the main rotor shaft to prevent over speeding, and on the Yaw motion. Twiflex brakes can be operated by dedicated control systems that interface with speed sensors to apply the brakes if the speed rises above pre-determined levels.



Winder and haulage applications

Twiflex brakes have gained wide respect and acceptance with International mining authorities for winder and haulage applications. This position has been achieved by paying close attention to customers needs and providing comprehensive customer support. Twiflex have recently developed the world's most powerful disc brakes to provide safe control for the world's largest winders. Twiflex brakes have a high level of technical specification including:

- Non dependence on single line components
- Theoretical infinite fatigue life
- Critical components non-destructive tested during manufacture

Calipers operate directly on the Koepe wheel or drum since there is no limitation on disc thickness or diameter.

INDUSTRIAL DISC BRAKES



PRODUCT BROCHURE

ADVANCED BRAKING TECHNOLOGY

i n t r o d u c t i o n

Twiflex Limited, with headquarters in Twickenham, England, specialise in the design, manufacture and supply of Advanced Braking Technology for Industrial Applications. With extensive in-house design, engineering, manufacturing and assembly facilities, Twiflex have a well-deserved reputation for quality and precision.

Founded in 1946, Twiflex have supplied approximately 500,000 brakes, frequently for critical applications, around the World. From textile machines in Bolton to the World's deepest mine shaft in South Africa, Twiflex brakes enjoy a premier status amongst Engineers and Operators in every type of Industry.

Although an approximate selection can be made by assessing the data contained within this brochure, it is always wise to contact a Twiflex agent directly for a more detailed proposal.

Whether you are looking to purchase the most advanced braking system in the World or simply component parts, we hope this brochure will serve as a useful guide.

c o n t e n t s

1	APPLICATIONS	2
2	BRAKE SYSTEM OVERVIEW	4
3	BRAKE CALIPER RANGE	
	MU Series	6
	MS Series	8
	MR Series	11
	MX Series	15
	GMX Series	20
	GMR Series	25
	Modular Series	28
4	DISC AND HUB ASSEMBLIES	35
5	PNEUMATIC CONTROLLERS	36
6	INTENSIFIERS	37
7	MONITOR UNITS	38
8	HYDRAULIC POWER UNITS	39
9	BRAKING CALCULATIONS	40



Conveyors

Disc brakes are used on conveyors for four main reasons:

- An emergency stop
- For normal stopping and parking
- Where one conveyor feeds another and there is a risk of over spill
- Wherever there exists a risk of personal injury particularly under ground

The brakes may be fitted to the tail drum, driving drum or motor shaft, but with long over ground conveyors, Twiflex recommend that the brake is fitted to the up stream end to prevent a catapult effect due to reversal of belt tension.

Twiflex has developed brake controllers ranging from simple on/off to the more sophisticated systems that interface with drive motor and speed sensors to provide specific starting and stopping profiles.



Wind turbines

Twiflex disc brakes can be used on wind energy generators on both the main rotor shaft to prevent over speeding, and on the Yaw motion. Twiflex brakes can be operated by dedicated control systems that interface with speed sensors to apply the brakes if the speed rises above pre-determined levels.



Winder and haulage applications

Twiflex brakes have gained wide respect and acceptance with International mining authorities for winder and haulage applications. This position has been achieved by paying close attention to customers needs and providing comprehensive customer support. Twiflex have recently developed the world's most powerful disc brakes to provide safe control for the world's largest winders. Twiflex brakes have a high level of technical specification including:

- Non dependence on single line components
- Theoretical infinite fatigue life
- Critical components non-destructive tested during manufacture

Calipers operate directly on the Koepe wheel or drum since there is no limitation on disc thickness or diameter.

Marine main propulsion

Twiflex brakes are fitted to the main propulsion system for three main reasons:

- Maintenance purposes, particularly while under way
- To assist and improve manoeuvrability
- Safety: the ability to stop the propellers turning in a very short time

The brake is usually mounted on the gearbox output flange, particularly when reversing gears are fitted, often in conjunction with Twiflex air start clutches and flexible couplings. Twiflex brakes are used on Naval ships around the world, in particular the Royal Navy, and by many tug and merchant fleet operators.



Crane hoists and travelling motions



Twiflex disc brakes are designed to operate in the most arduous conditions, typically in the steel industry where the operating environment is extreme, and the container industry where reliable operation all year round is expected. Twiflex brakes are often specified for the main hoist, acting as service brakes mounted on the input shaft and as emergency brakes mounted on the output shaft or directly on the main drum. Brakes are also fitted on the travelling trolley/carriage and to the boom hoist as found on container cranes. Twiflex have developed an electro-hydraulic power pack to operate several independent brake circuits in fail to safe condition, providing a complete braking system.

Escalators and elevators

Twiflex has gained considerable experience with brake installations on escalators and elevators, in particular low speed auxiliary brakes for escalators. Standard brake designs have been adapted to suit particular installations. Twiflex brake systems have been installed on some of the world's longest escalators, providing controlled braking both to the high and low speed brakes.



Marine main propulsion

Twiflex brakes are fitted to the main propulsion system for three main reasons:

- Maintenance purposes, particularly while under way
- To assist and improve manoeuvrability
- Safety: the ability to stop the propellers turning in a very short time

The brake is usually mounted on the gearbox output flange, particularly when reversing gears are fitted, often in conjunction with Twiflex air start clutches and flexible couplings. Twiflex brakes are used on Naval ships around the world, in particular the Royal Navy, and by many tug and merchant fleet operators.



Crane hoists and travelling motions



Twiflex disc brakes are designed to operate in the most arduous conditions, typically in the steel industry where the operating environment is extreme, and the container industry where reliable operation all year round is expected. Twiflex brakes are often specified for the main hoist, acting as service brakes mounted on the input shaft and as emergency brakes mounted on the output shaft or directly on the main drum. Brakes are also fitted on the travelling trolley/carriage and to the boom hoist as found on container cranes. Twiflex have developed an electro-hydraulic power pack to operate several independent brake circuits in fail to safe condition, providing a complete braking system.

Escalators and elevators

Twiflex has gained considerable experience with brake installations on escalators and elevators, in particular low speed auxiliary brakes for escalators. Standard brake designs have been adapted to suit particular installations. Twiflex brake systems have been installed on some of the world's longest escalators, providing controlled braking both to the high and low speed brakes.



Brake calipers

Twiflex offer the largest range of industrial disc brake calipers in the world. The majority of direct acting brake calipers are fitted with a retraction device. The spring applied brakes are retracted by pneumatic or hydraulic pressure or electrically.

In general, pneumatic brakes are best suited for stopping duties in the low to medium torque range and for tension control applications, whilst the hydraulic brakes meet the high torque requirements. Spring applied brakes are used where braking must be maintained in the event of supply system failure. Mechanically applied brakes are appropriate where no power supply is available and for light tensioning duties when precise control is not required. They may also be specified when designers wish to use their own actuating means.



Couplings

Twiflex manufacture a large range of rubber-based light, medium and heavy-duty couplings. The shaft coupling, which can be combined with a brake disc, is a critical interface between components of a transmission system. Twiflex engineers will be very pleased to discuss, analyse, advise and select a coupling to suit your requirements, and give whatever technical support as required.

Discs

Twiflex manufacture and supply a large range of discs and mounting hubs. These can be supplied pilot bored or fully machined to suit your mounting arrangements. Discs can be supplied to fit shaft couplings.

Twiflex can also supply special discs for specific applications, examples include a split disc for marine applications.



Brake pads



Twiflex are able to make realistic assessments of expected pad life. These calculations are based on both analytical and test data.

Pad life is affected by the area of the brake pad, the energy dissipated in braking, and the maximum braking path temperature. Pad life should be considered if the duty includes:

- General braking duties
- High inertia/speed duties
- Tensioning duties

Hydraulic power units

Twiflex offer several types of electro-hydraulic power units. These units require careful selection since pressure and capacity must be compatible with both the type and number of calipers employed.

The LC range of electro-hydraulic power units has been designed to provide a basic on/off control for a range of Twiflex spring applied and direct acting calipers.

The MP range of electro-hydraulic power units has been designed to provide an advanced and flexible means of brake control.

Customised Power Units are available on request



Pneumatic controllers

Twiflex offer a range of controllers and interfacing devices that allow pneumatic brake calipers to be connected to an air supply and interface with a control system.

We also offer tension controllers that provide a well-proven and economic method of web tension control for the paper, textile, plastics and steel strip industries.

Intensifier units

For situations where the use of an electro-hydraulic power unit is not appropriate, Twiflex offer the following:

- Foot pedal units
- Air hydraulic intensifiers
- Combination intensifiers

Monitoring equipment

Every brake installation requires monitoring visually, mechanically or electrically; particularly spring applied safety brakes. Twiflex can supply a range of electro-mechanical and electronic standard monitoring units and limit switches that will indicate a combination of brake on/off, pad wear and pad replacement.

Materials, finishes and traceability

Twiflex are approved to BS EN ISO 9001:1994 and can offer material and dimensional certification by Lloyds Register or other similar authorities. All units are supplied to standard Twiflex finishes but can be given full external environmental protection to suit marine and similar applications.



▼ MU Disc brake caliper

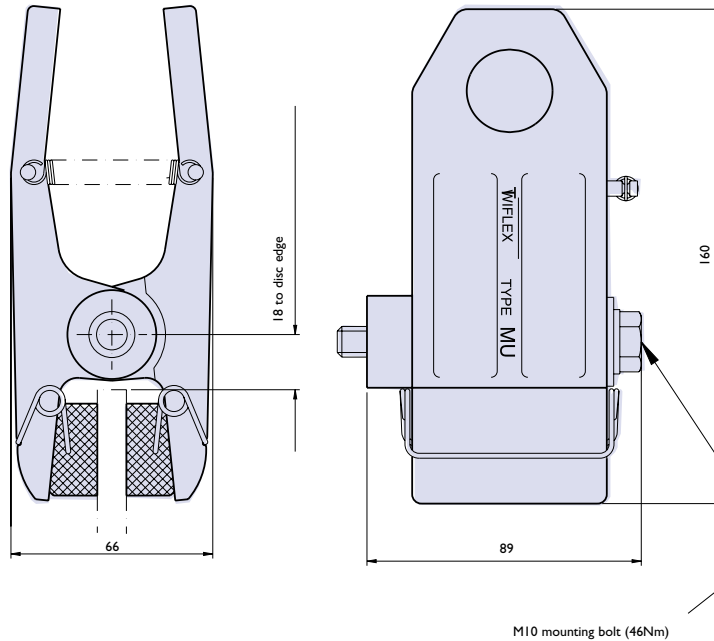

The 'MU' series of disc brake calipers is the smallest in the Twiflex range and is designed for light duty stopping and holding duties.

Left or right hand units are available.

The range of calipers should be operated using dry, filtered and non-lubricated compressed air. Pneumatic brakes require a control valve, which may be operated either manually, or by pneumatic or electrical signal.

Minimum disc diameter for the MU caliper is 150mm.

This range of calipers are normally used with 8mm thick discs, but with revised thruster mounting arrangement they can be used with standard Twiflex discs of 12.7mm thick. (see section 4)

The ratings shown on the graphs are based on fully bedded and conditioned brake pads with nominal friction coefficient $\mu = 0.4$

Fixing Bolt customer supply. Twiflex Disc Brakes must be used with Twiflex asbestos free brake pads.

Effective Disc Radius = Actual Disc Radius (m) - 0.02m

MU
series



▼ MU3

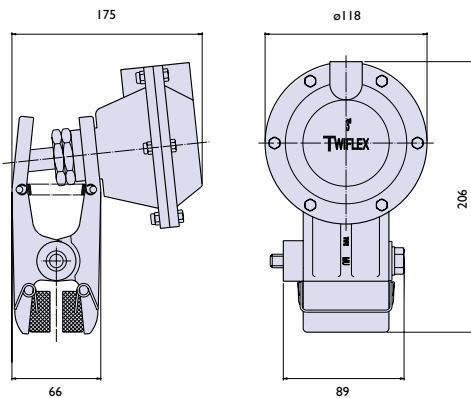

Pneumatically applied – Spring released

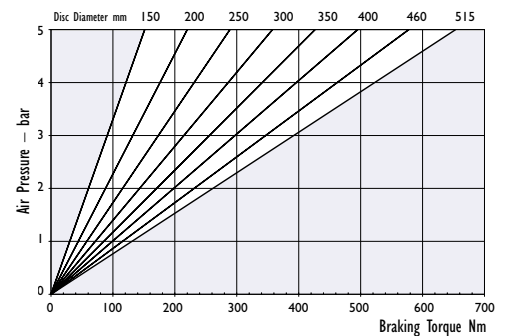

Maximum Pressure 5 bar
 Maximum Braking Force = 2.75kN@ 5 bar
 Weight of caliper and thruster - 1.9kg
 Weight of thruster only - 1.15kg
 Volume displacement of thruster at 13mm stroke = 46ml

▼ MUP

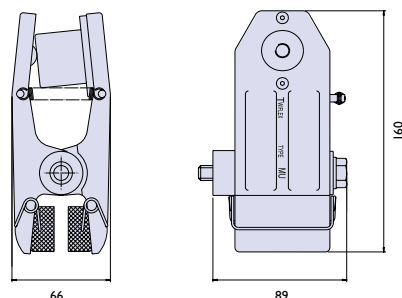

Pneumatically applied – Spring released

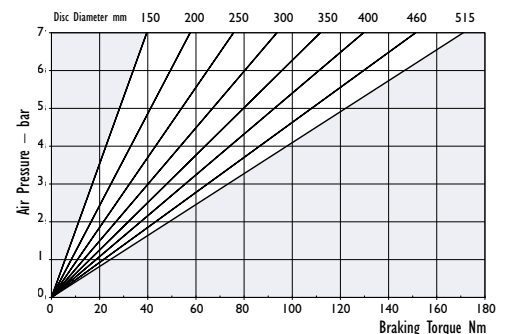

Maximum Pressure 7 bar
 Maximum Braking Force = 0.72kN@ 7 bar
 Weight of caliper and thruster - 0.8kg
 Weight of thruster only - 0.05kg
 Volume displacement of thruster at 6mm stroke = 4ml

▼ MUS2

Spring applied – Pneumatically released

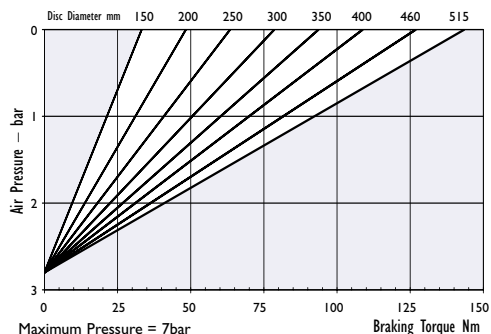
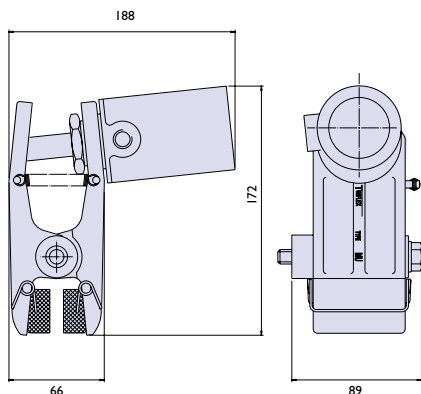

Maximum Pressure = 7bar
 Minimum Pressure for full retraction = 4.3bar
 Maximum Braking Force = 0.6kN
 Weight of caliper and thruster – 1.36kg
 Weight of thruster only – 0.61kg
 Volume displacement of thruster at full retraction = 20ml

▼ MUS3

Spring applied – Pneumatically released

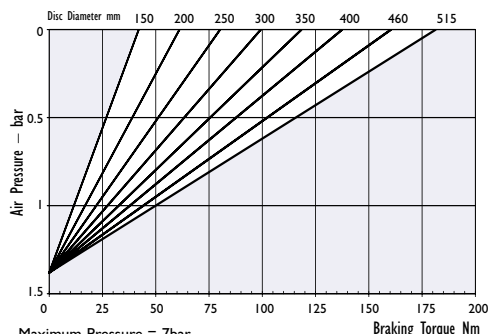
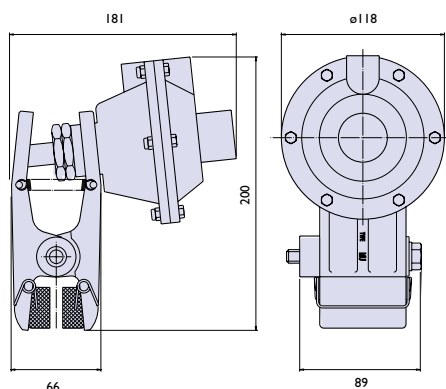

Maximum Pressure = 7bar
 Minimum Pressure for full retraction = 1.75bar
 Maximum Braking Force = 0.76kN
 Weight of caliper and thruster – 2.2kg
 Weight of thruster only – 1.45kg
 Volume displacement of thruster at full retraction = 46ml

▼ MUS4

Spring applied – Pneumatically released

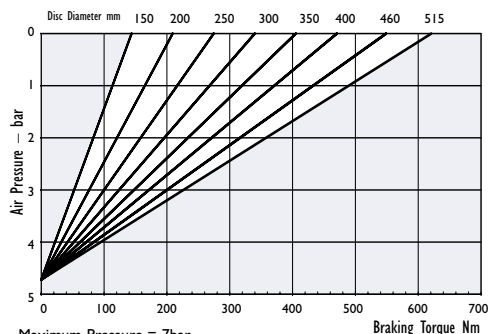
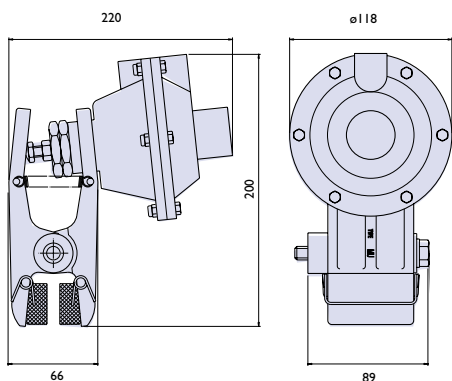

Maximum Pressure = 7bar
 Minimum Pressure for full retraction = 6.2bar
 Maximum Braking Force = 2.6kN
 Weight of caliper and thruster – 2.24kg
 Weight of thruster only – 1.49kg
 Volume displacement of thruster at full retraction = 46ml

▼ MUH

Mechanically applied – Hand operated

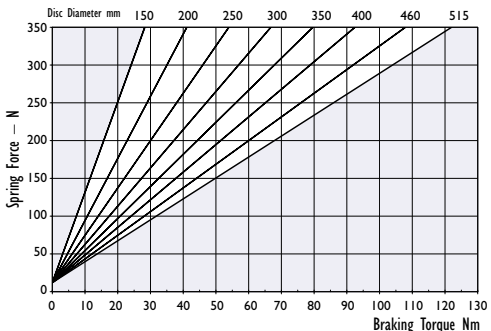
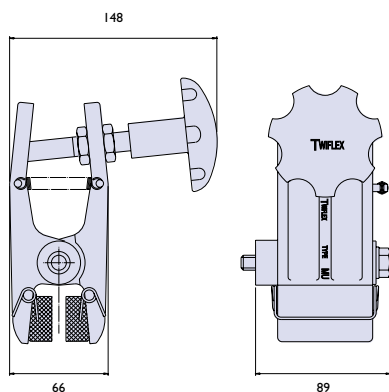

Weight of caliper and thruster – 1.9kg
 Weight of handknob assembly only – 1.15kg
 Maximum Braking Force = 0.51kN

MU
series



3

Brake caliper range

▼ MS Disc brake caliper

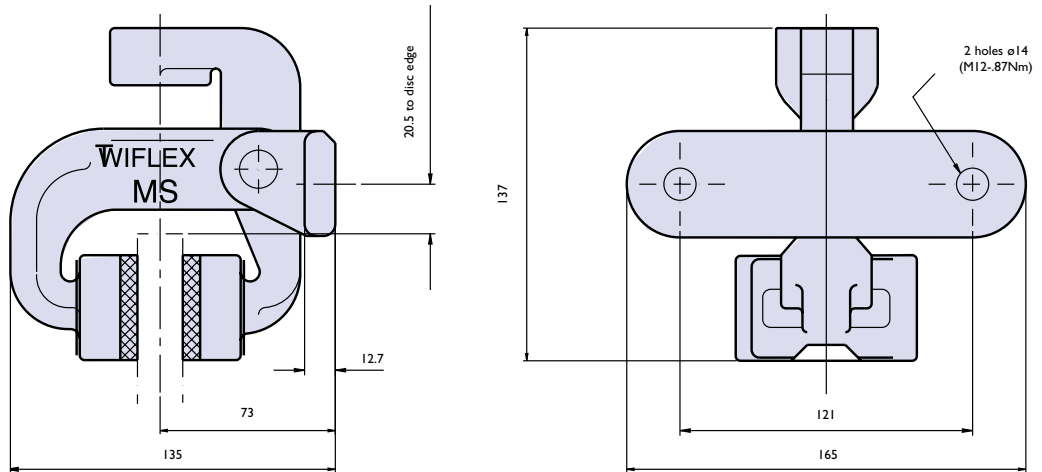

[View Data Sheet](#)

The Twiflex MS disc brake calipers are used with brake discs 12.7mm thick. They may be used with the majority of Twiflex actuators.

The range of pneumatically operated brakes use dry and filtered compressed air at pressures up to 7 bar. Pneumatic brakes require a control valve, which may be operated either manually, or by pneumatic or electrical signal.

Normally one or two brake calipers will be used per disc, mounted horizontally in the 3 and/or 9 o'clock positions, to prevent bias due to self weight and, hence, rubbing on one brake pad.

A range of standard discs is available from Twiflex, (see section 4).

Minimum disc diameter for the MS caliper is 250mm.

The ratings shown on the graphs are based on fully bedded and conditioned brake pads with nominal friction coefficient $\mu = 0.4$. Twiflex Disc Brakes must be used with Twiflex asbestos free brake pads.

Effective Disc Radius = Actual Disc Radius (m) - 0.03m

MS
series



▼ MSA

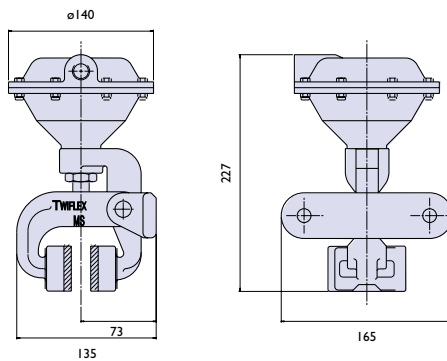

[View Data Sheet](#)

Pneumatically applied – Spring released

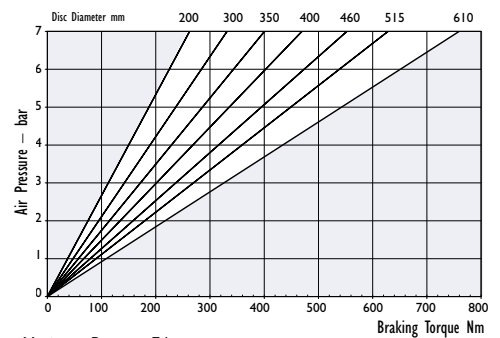

Maximum Pressure 7 bar
 Maximum Braking Force = 2.76kN @ 7 bar
 Weight of caliper and thruster - 3.8kg
 Weight of thruster only - 2.1kg
 Volume displacement of thruster at full stroke = 300ml

▼ MSD

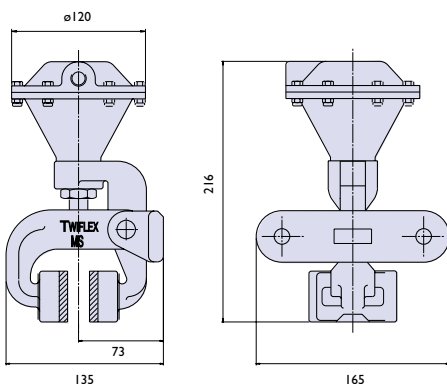

[View Data Sheet](#)

Pneumatically applied – Spring released

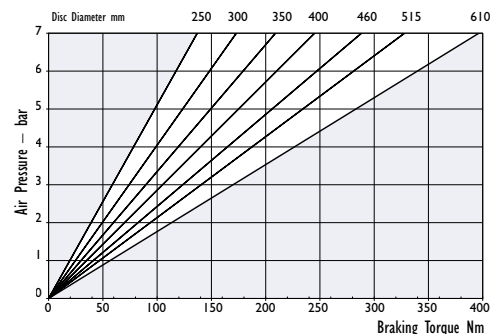

Maximum Pressure 7 bar
 Maximum Braking Force = 1.44kN @ 7 bar
 Weight of caliper and thruster - 2.6kg
 Weight thruster only - 0.9g
 Volume displacement of thruster at full stroke = 150ml

▼ MSE

Pneumatically applied – Spring released

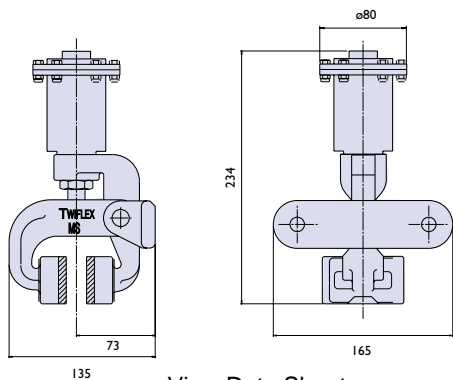

View Data Sheet

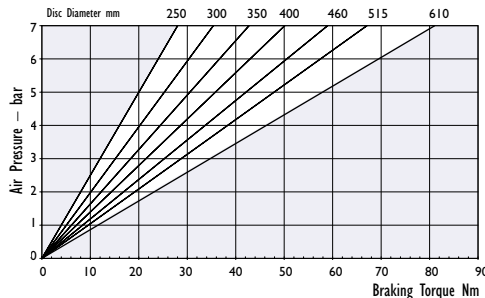

Maximum Pressure 7 bar
 Maximum Braking Force = 0.29kN @ 7 bar
 Weight of caliper and thruster - 2.08kg
 Weight of thruster only - 0.41kg
 Volume displacement of thruster at full stroke = 8ml

▼ MSG

Pneumatically applied – Spring released

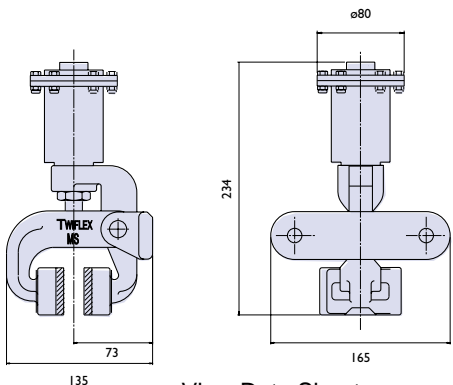

View Data Sheet

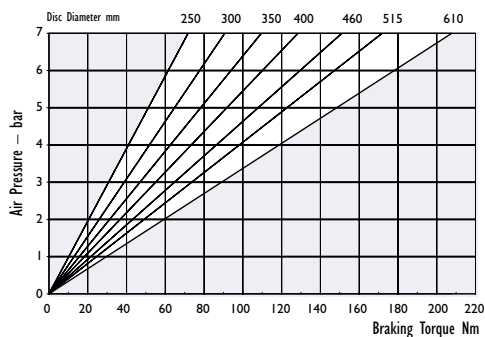

Maximum Pressure 7 bar
 Maximum Braking Force = 0.76kN @ 7 bar
 Weight of caliper and thruster - 2.06kg
 Weight of thruster only - 0.39kg
 Volume displacement of thruster at full stroke = 21ml

MS
series



▼ MSF

Mechanically applied – Lever operated

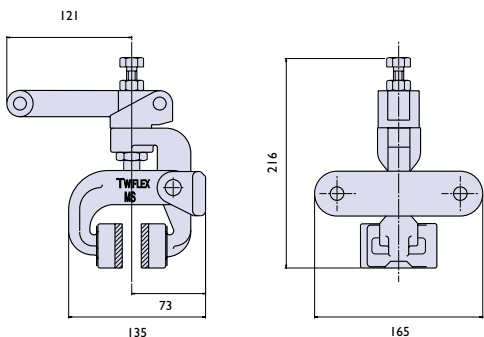

View Data Sheet

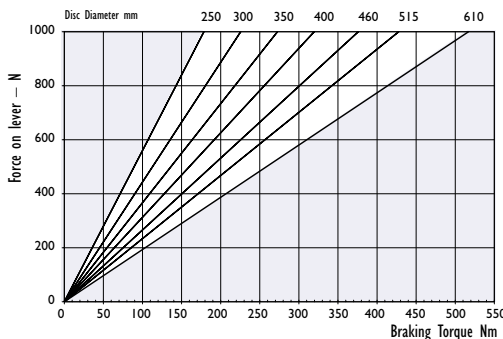

Maximum Braking Force = 1.88kN @ 0.8kN force on lever
 Weight of caliper and lever assembly - 2.3kg
 Weight of lever assembly only - 0.63kg

▼ MSH

Mechanically applied – Hand operated

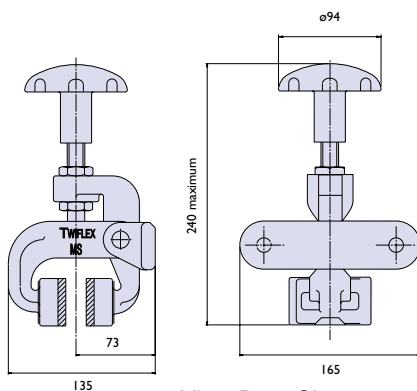

View Data Sheet

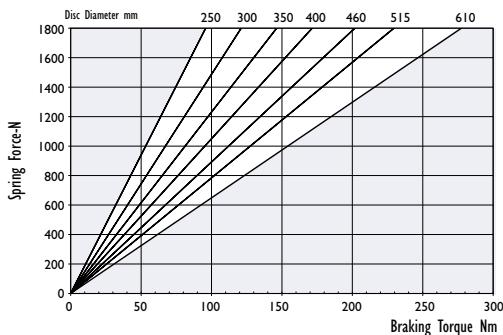

Maximum Braking Force = 1.01kN
 Weight of caliper and handwheel assembly - 2.7kg
 Weight of handwheel assembly only - 1.03kg

MS
series



▼ MSK - Self Adjusting

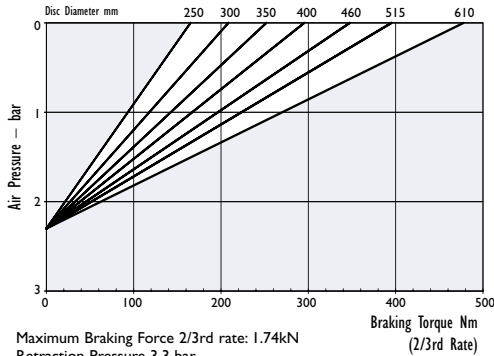
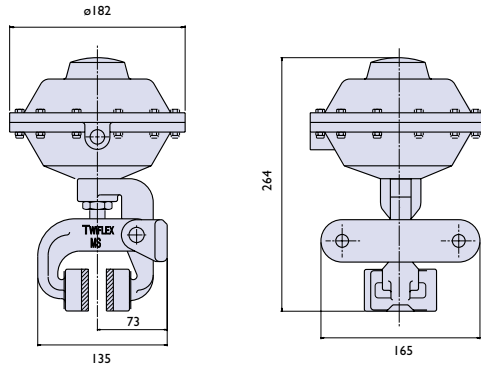

Maximum Braking Force 2/3rd rate: 1.74kN
Retraction Pressure 3.3 bar
Weight of caliper and thruster - 5.17kg
Weight of thruster only - 3.5kg
Volume displacement of thruster at full retraction = 950ml

[View Data Sheet](#)

Spring applied – Pneumatically released

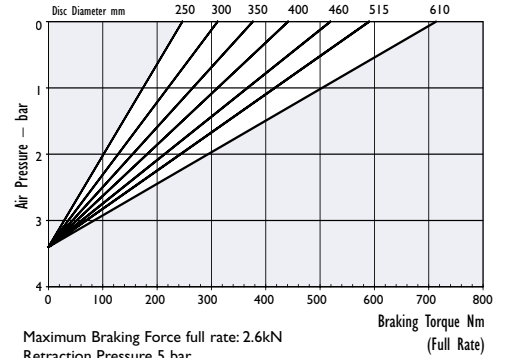

Maximum Braking Force full rate: 2.6kN
Retraction Pressure 5 bar
Weight of caliper and thruster - 5.17kg
Weight of thruster only - 3.5kg
Volume displacement of thruster at full retraction = 950ml

▼ MSL - Self Adjusting

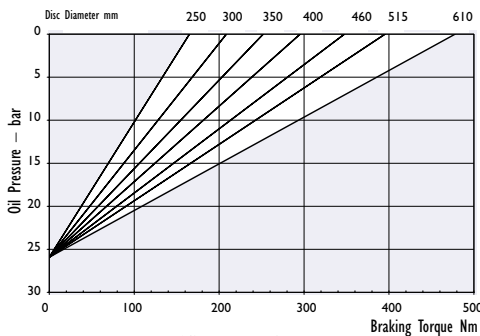
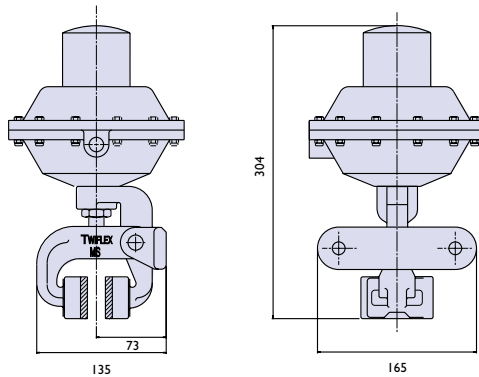

Maximum Braking Force 2/3rd rate: 1.74kN
Retraction Pressure 33 bar
Weight of caliper and thruster - 5.67kg
Weight of thruster only - 4kg
Volume displacement of thruster at 4mm retraction = 5ml

[View Data Sheet](#)

Spring applied – Hydraulically released

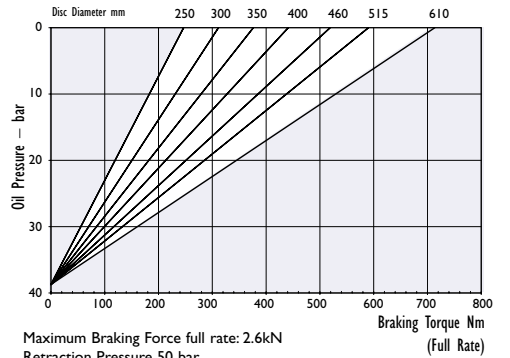

Maximum Braking Force full rate: 2.6kN
Retraction Pressure 50 bar
Weight of caliper and thruster - 5.67kg
Weight of thruster only - 4kg
Volume displacement of thruster at 4mm retraction = 5ml

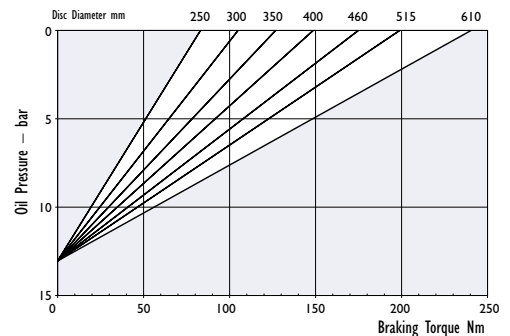

Maximum Braking Force 1/3rd rate: 0.87kN
Retraction Pressure 17 bar
Weight of caliper and thruster - 5.67kg
Weight of thruster only - 4kg
Volume displacement of thruster at 4mm retraction = 5ml

▼ MR Disc brake caliper

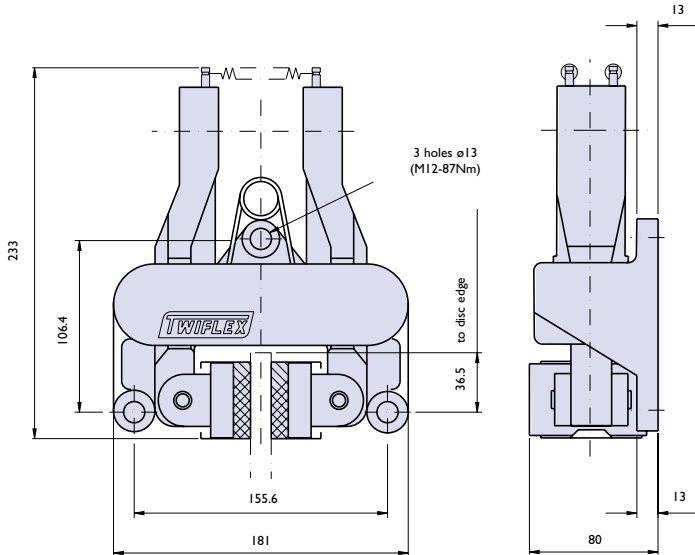

[View Data Sheet](#)

▼ MR2 Disc brake caliper

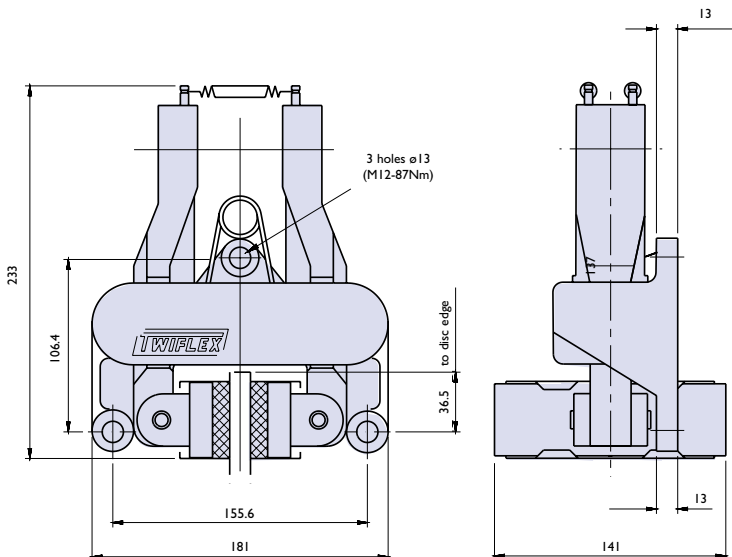

[View Data Sheet](#)

The Twiflex MR disc brake calipers are used with brake discs of 12.7mm and 25mm thick. They may be used with any of the Twiflex series of actuators. The range of pneumatically operated brakes, use dry and filtered compressed air at pressures up to 7 bar. Pneumatic brakes require a control valve, which may be operated either manually, or by pneumatic or electrical signal.

Normally one or two brakes will be used per disc, but the number may be increased, depending on disc size.

The brake units can be positioned at any angle around the periphery of the disc, but ideally they should be mounted horizontally (in 3 or 9 o'clock positions) in relation to the disc. If a caliper is mounted at an angle greater than 10° from the horizontal it should be fitted with an equalising link. This applies also to calipers used on vertical shaft installations.

Ranges of standard discs are available from Twiflex, (see section 4).

Minimum disc diameter for the MR caliper is 250mm and the MR2 is 300mm.

The ratings shown on the graphs are based on fully bedded and conditioned brake pads with nominal friction coefficient $\mu = 0.4$.

Twiflex disc brakes must be used with Twiflex asbestos free brake pads.

Effective Disc Radius = Actual Disc Radius (m) - 0.03m

MR
series



3

Brake caliper range

MR series



▼ MRA

Pneumatically applied – Spring released

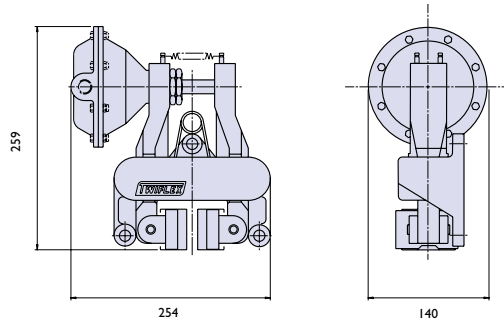

View data sheet

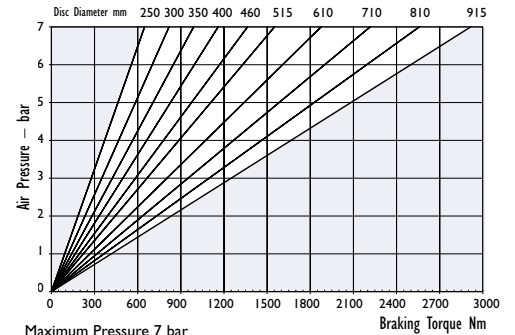

Maximum Pressure 7 bar
 Maximum Braking Force = 6.9kN @ 7 bar
 Weight of MR caliper and thruster - 8.0kg
 Weight of MR2 caliper and thruster - 8.5kg
 Weight of thruster only - 1.5kg
 Volume displacement of thruster at full stroke = 300ml

▼ MRB

Pneumatically applied – Spring released

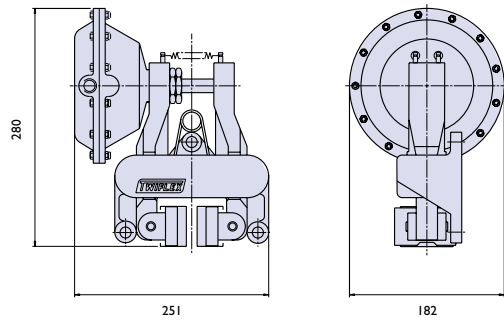

View Data Sheet

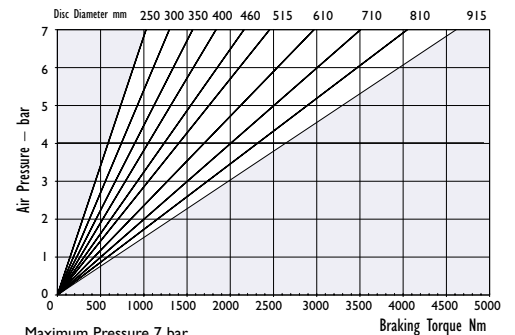

Maximum Pressure 7 bar
 Maximum Braking Force = 10.8kN @ 7 bar
 Weight of MR caliper and thruster - 8.56kg
 Weight of MR2 caliper and thruster - 9.06kg
 Weight of thruster only - 2.06kg
 Volume displacement of thruster at full stroke = 426ml

▼ MRD

Pneumatically applied – Spring released

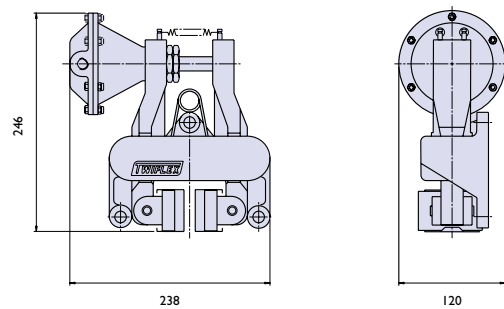

View Data Sheet

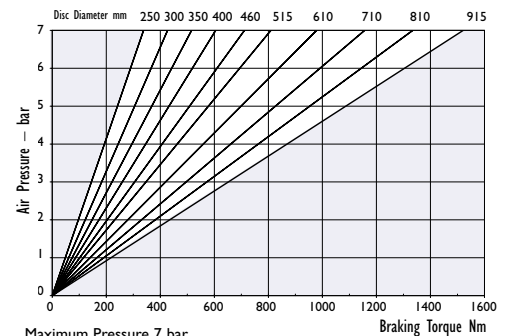

Maximum Pressure 7 bar
 Maximum Braking Force = 3.6kN @ 7 bar
 Weight of MR caliper and thruster - 8.0kg
 Weight of MR2 caliper and thruster - 8.5kg
 Weight of thruster only - 1.5kg
 Volume displacement of thruster at full stroke = 150ml

▼ MRE

Pneumatically applied – Spring released

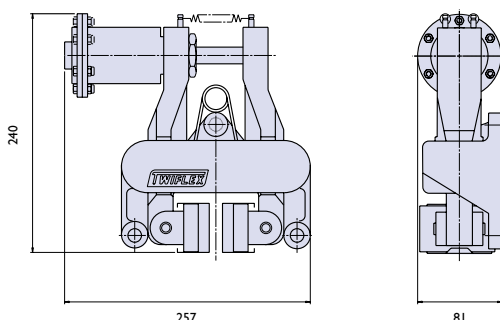

View Data Sheet

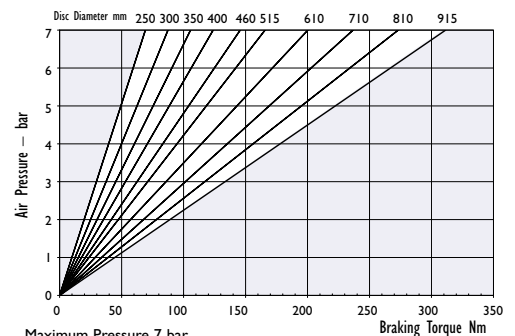

Maximum Pressure 7 bar
 Maximum Braking Force = 0.74kN @ 7 bar
 Weight of MR caliper and thruster - 6.84kg
 Weight of MR2 caliper and thruster - 7.34kg
 Weight of thruster only - 0.34kg
 Volume displacement of thruster at full stroke = 25ml

▼ MRG

Pneumatically applied – Spring released

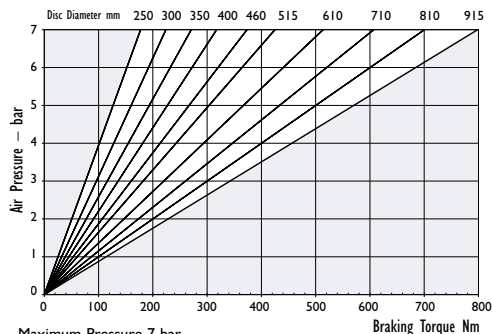
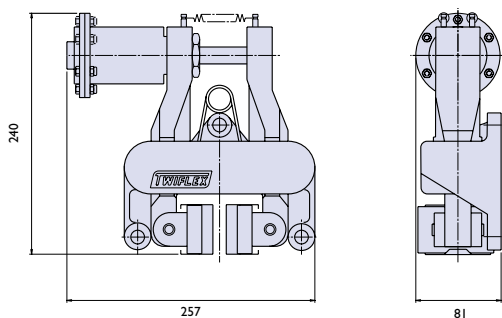

Maximum Pressure 7 bar
 Maximum Braking Force = 1.9kN @ 7 bar
 Weight of MR caliper and thruster - 6.8kg
 Weight of MR2 caliper and thruster - 7.3kg
 Weight of thruster only - 0.3kg
 Volume displacement of thruster at full stroke = 64ml

[View Data Sheet](#)

▼ MRH

Mechanically applied – Lever operated

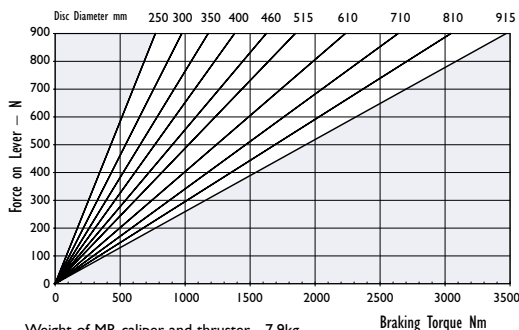
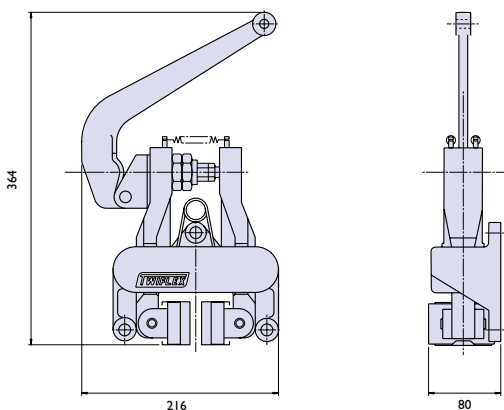

Weight of MR caliper and thruster - 7.9kg
 Weight of MR2 caliper and thruster - 8.4kg
 Weight of lever assembly only - 1.4kg
 Maximum Braking Force = 8.3kN @ 0.9kN force on lever

[View Data Sheet](#)

▼ MRW

Mechanically applied – Hand operated

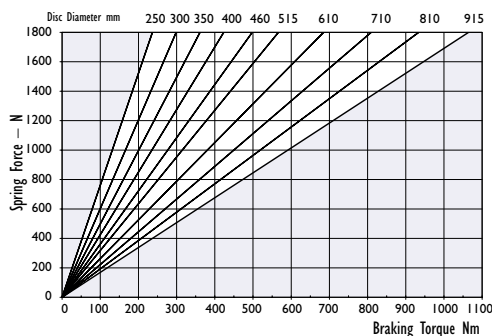
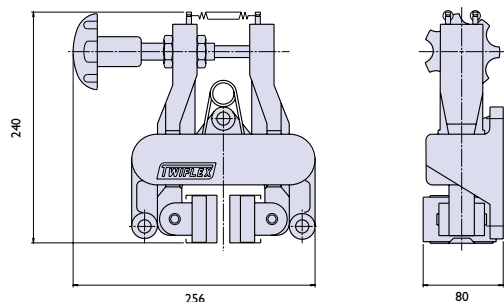

Weight of MR caliper and hand knob assembly - 7.8kg
 Weight of MR2 caliper and thruster - 8.3kg
 Weight of hand knob assembly only - 1.3kg
 Maximum Braking Force = 2.68kN

[View Data Sheet](#)

MR
series



▼ MRK - Self Adjusting

Spring applied – Pneumatically released

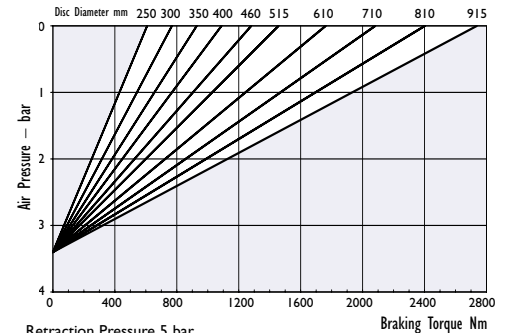
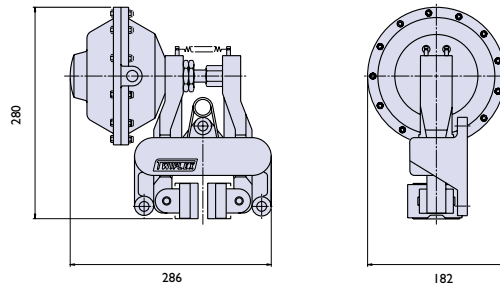

Retraction Pressure 5 bar
 Maximum Braking Force full rate: 6.4kN
 Weight of MR caliper and thruster - 10.0kg
 Weight of MR2 caliper and thruster - 10.5kg
 Weight of thruster only - 3.5kg
 Volume displacement of thruster at full retraction is 950ml

View Data Sheet

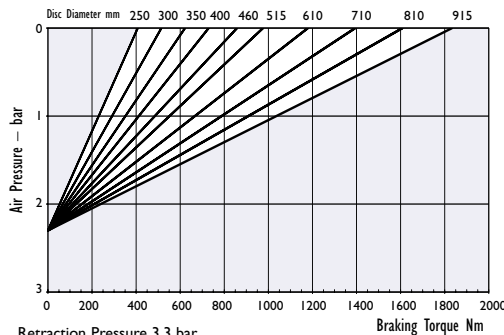

Retraction Pressure 3.3 bar
 Maximum Braking Force 2/3rd rate: 4.3kN
 Weight of MR caliper and thruster - 10.0kg
 Weight of MR2 caliper and thruster - 10.5kg
 Weight of thruster only - 3.5kg
 Volume displacement of thruster at full retraction is 950ml

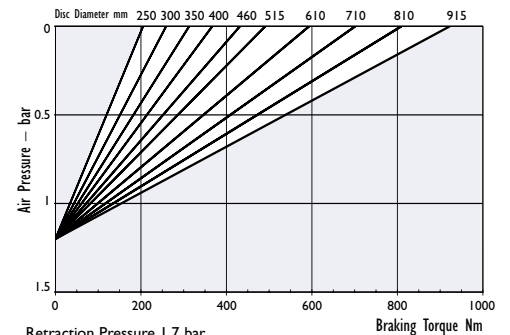

Retraction Pressure 1.7 bar
 Maximum Braking Force 1/3rd rate: 2.2kN
 Weight of MR caliper and thruster - 10.0kg
 Weight of MR2 caliper and thruster - 10.5kg
 Weight of thruster only - 3.5kg
 Volume displacement of thruster at full retraction is 950ml

MR

series



▼ MRL - Self Adjusting

Spring applied – Hydraulically released

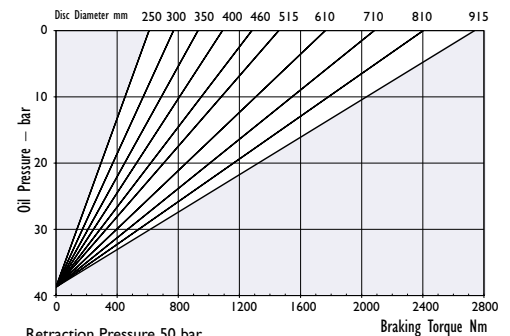
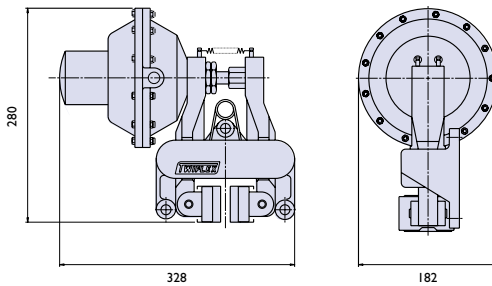

Retraction Pressure 50 bar
 Maximum Braking Force full rate: 6.4kN
 Weight of MR caliper and thruster - 10.5kg
 Weight of MR2 caliper and thruster - 11kg
 Weight of thruster only - 4kg
 Volume displacement of thruster at 4mm retraction = 5ml

View Data Sheet

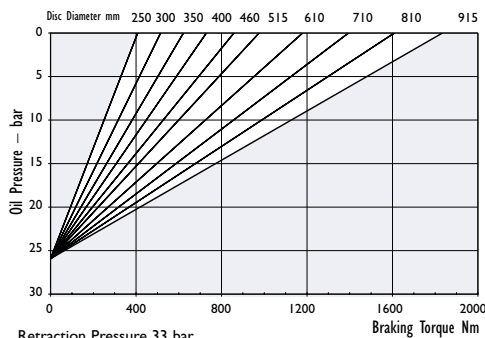

Retraction Pressure 33 bar
 Maximum Braking Force 2/3rd rate: 4.3kN
 Weight of MR caliper and thruster - 10.5kg
 Weight of MR2 caliper and thruster - 11kg
 Weight of thruster only - 4kg
 Volume displacement of thruster at 4mm retraction = 5ml

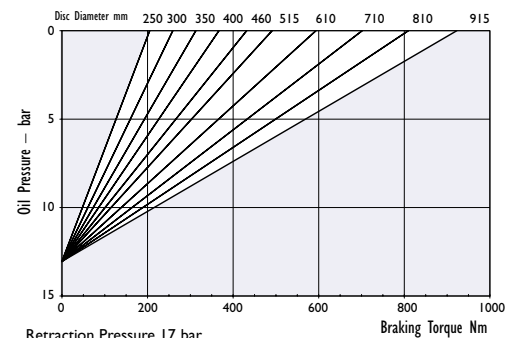

Retraction Pressure 17 bar
 Maximum Braking Force 1/3rd rate: 2.2kN
 Weight of MR caliper and thruster - 10.5kg
 Weight of MR2 caliper and thruster - 11kg
 Weight of thruster only - 4kg
 Volume displacement of thruster at 4mm retraction = 5ml

▼ MX Disc brake caliper

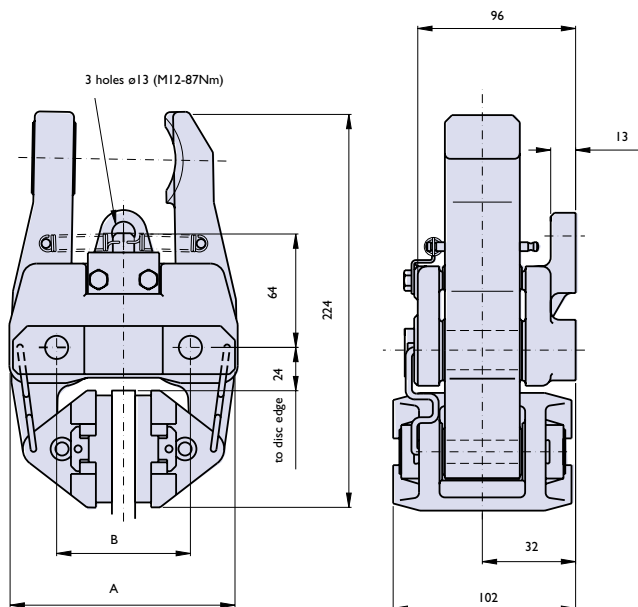

	Disc Thickness	A	B
MX13	13	130	75
MX25	25	134	84
MX30	30	142	75
MX40	40	150	84

View Data Sheet

▼ SMX Disc Brake Caliper

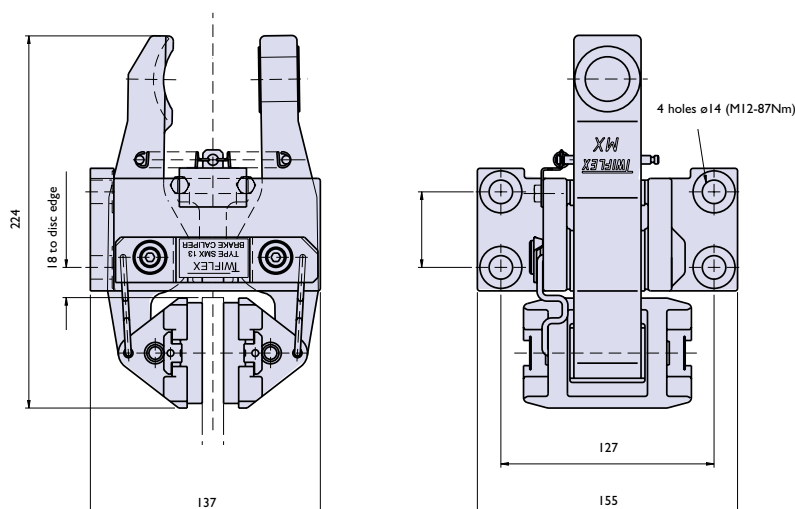

The Twiflex MX13, MX25, MX30 & MX40 disc brake calipers are used with brake discs of 12.7, 25.4, 30 & 40mm thickness respectively. The SMX is used with a 12.7mm thick disc only. They may be used with any of the Twiflex series of actuators.

Features patented, compliant link mechanism to ensure uniform pad wear.

The range of pneumatically operated brakes, use dry and filtered compressed air at pressures up to 7 bar. Pneumatic brakes require a control valve, which may be operated either manually, or by pneumatic or electrical signal.

Normally one or two brakes will be used per disc, but the number may be increased, depending on disc size.

The brake units can be positioned at any angle around the periphery of the disc, but ideally they should be mounted horizontally (in 3 or 9 o'clock positions) in relation to the disc.

If a caliper is mounted at an angle greater than 10° from the horizontal it should be fitted with an inclined mounting kit or equalising link. This applies also to calipers used on vertical shaft installations.

A range of standard discs of 12.7mm and 25.4mm thickness are available from Twiflex,

(see section 4).

Minimum disc diameter for the MX caliper is 300mm.

The ratings shown on the graphs are based on fully bedded and conditioned brake pads with nominal friction coefficient $\mu = 0.4$. Twiflex Disc Brakes must be used with Twiflex asbestos free brake pads.

Effective Disc Radius = Actual Disc Radius (m) - 0.033m

MX

series



3

Brake caliper range

MX
series



▼ MXA

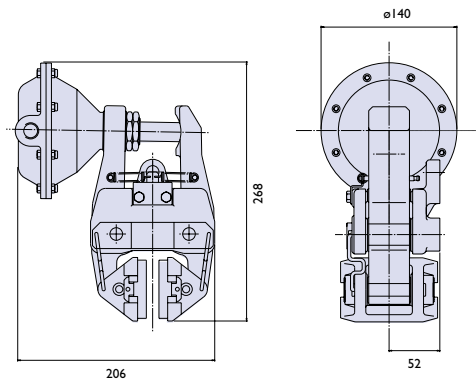

View Data Sheet

Pneumatically applied – Spring released

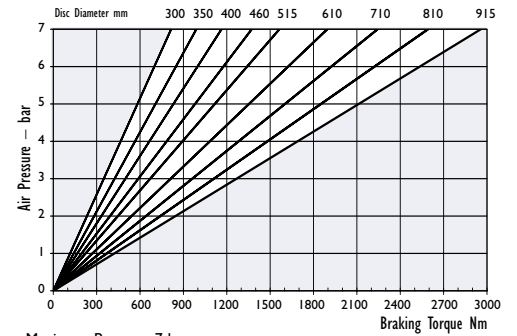

Maximum Pressure 7 bar
 Maximum Braking Force = 6.9kN @ 7 bar
 Weight of caliper and thruster - 8.35kg
 Weight of thruster only - 1.35kg
 Volume displacement of thruster at full stroke = 300ml

▼ MXB

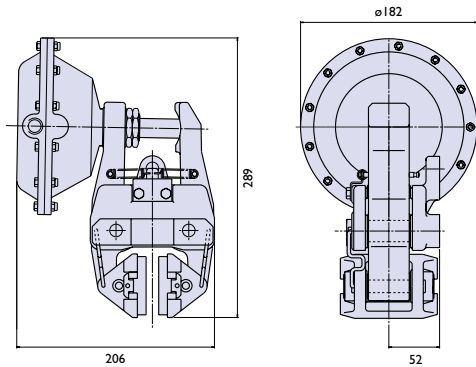

View Data Sheet

Pneumatically applied – Spring released

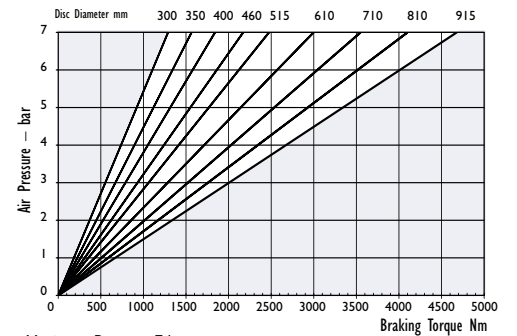

Maximum Pressure 7 bar
 Maximum Braking Force = 11kN @ 7 bar
 Weight of caliper and thruster - 9.06kg
 Weight of thruster only - 2.06kg
 Volume displacement of thruster at full stroke = 426ml

▼ MXD

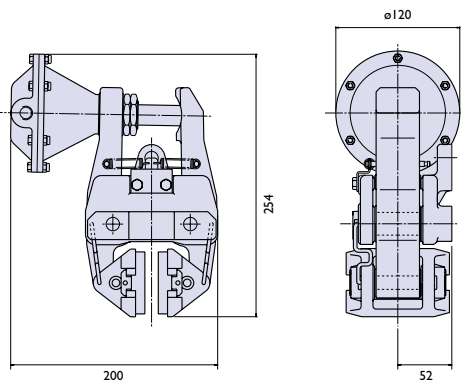

View Data Sheet

Pneumatically applied – Spring released

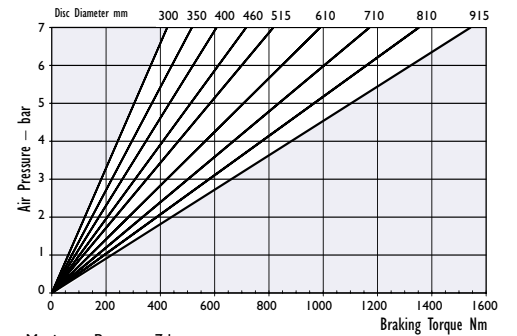

Maximum Pressure 7 bar
 Maximum Braking Force = 3.6kN @ 7 bar
 Weight of caliper and thruster - 8.12kg
 Weight of thruster only - 1.12kg
 Volume displacement of thruster at full stroke = 150ml

▼ MXE

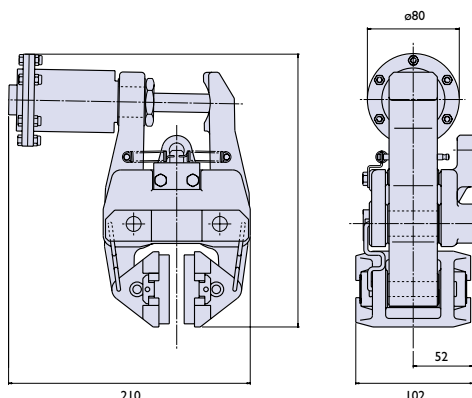

View Data Sheet

Pneumatically applied – Spring released

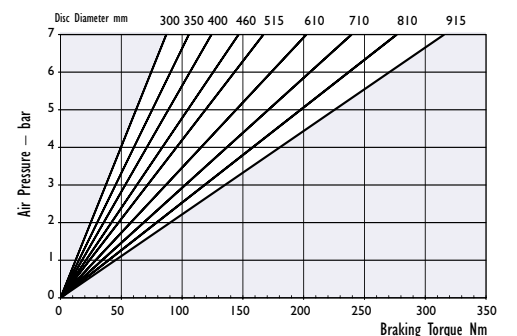

Maximum Pressure 7 bar
 Maximum Braking Force = 0.74kN @ 7 bar
 Weight of caliper and thruster - 7.34kg
 Weight of thruster only - 0.34kg
 Volume displacement of thruster at full stroke = 25ml

▼ **MXG**

Pneumatically applied – Spring released

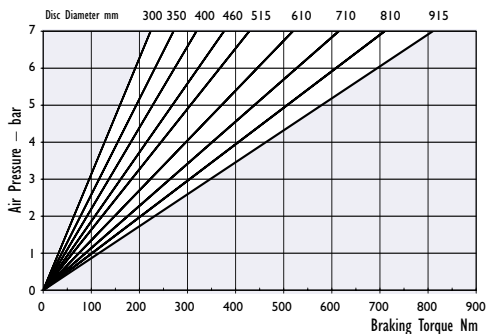
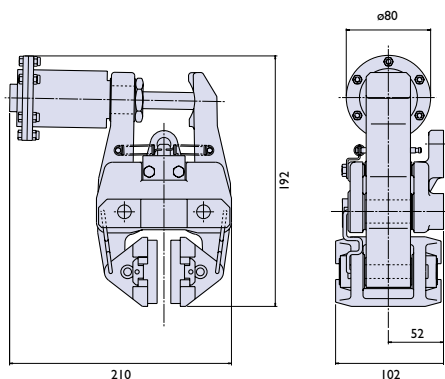

Maximum Pressure 7 bar
 Maximum Braking Force = 1.9kN @ 7 bar
 Weight of caliper and thruster - 7.3kg
 Weight of thruster only - 0.3kg
 Volume displacement of thruster at full stroke = 64ml

[View Data Sheet](#)

▼ **MXH**

Mechanically applied – Lever Operated

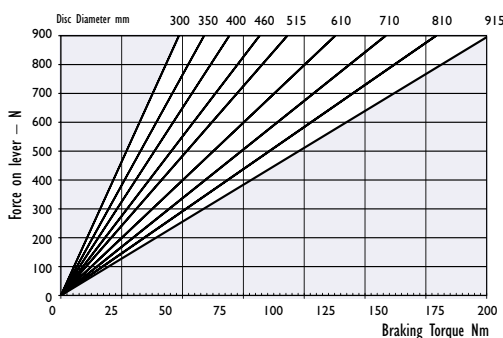
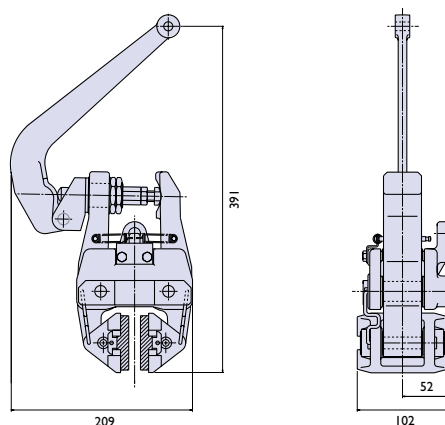

Weight of caliper and lever assembly - 8.4kg
 Weight of lever assembly only - 1.4kg
 Maximum Braking Force = 8.3kN @ 0.9kN force on lever

[View Data Sheet](#)

▼ **MXW**

Mechanically applied – Hand Operated

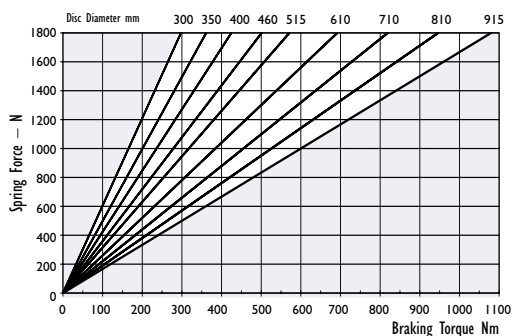
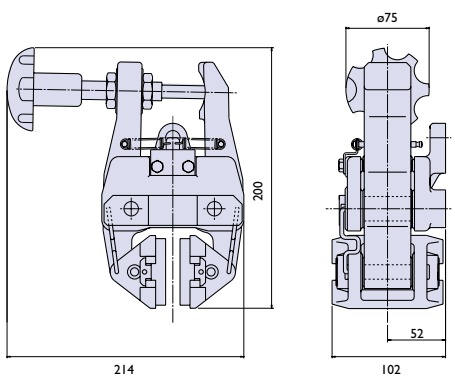

Weight of caliper and handwheel assembly - 8.3kg
 Weight of handwheel assembly only - 1.3kg
 Maximum Braking Force = 2.68kN

[View Data Sheet](#)

MX
series



3

Brake caliper range

MX
series



▼ MXSE

Spring Applied - Electromagnetically released

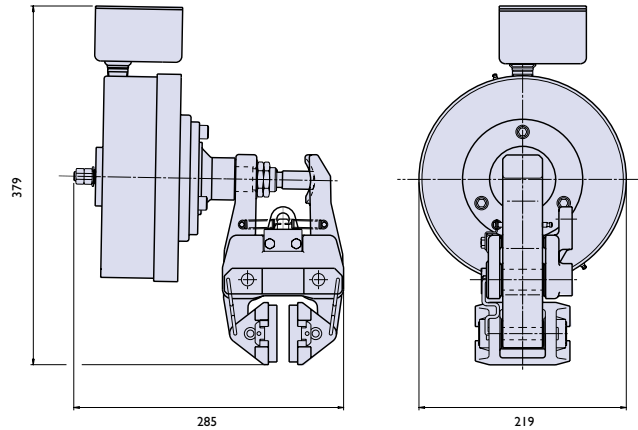

The MXSE is suitable for most medium to heavy duty holding and emergency stop applications. The design ensures long life, with fully potted coils protecting against harsh environments.

A wide range of coil voltages is available, from 12VDC to 250VDC the standard units being 100VDC. The thruster contains two electromagnet coils. A release coil (high current) and a holding coil (low current). Power is simultaneously applied to both coils in order to release the brake. After 1-2 seconds the supply voltage to the release coil is removed. The holding coil remains energised, maintaining the brake in its released state.

The brake units should ideally be mounted horizontally (in 3 or 9 o'clock positions) in relation to the disc. The use of an inclined mounting kit will allow the caliper to be mounted at an angle.

The maximum angle the MXSE should be mounted from the horizontal is 10°.

A range of standard discs are available from Twiflex, (see section 4).

Maximum braking force 5.2kN

▼ EMX - Self Adjusting

Spring applied – Electrically released

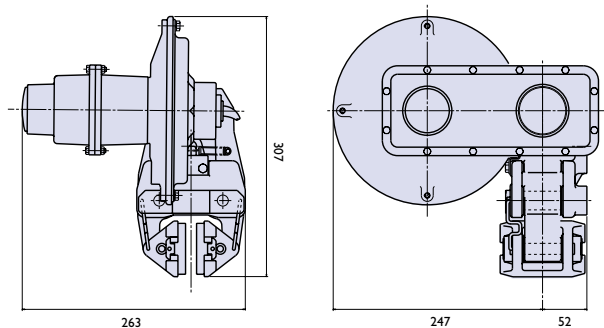

The EMX is a spring applied brake which is released by a ball screw mechanism.

The drive is provided by a 175W pancake motor, which gives ample power whilst having a minimum space requirement.

The actuator features a patented self adjusting mechanism. As the pads wear the mechanism adjusts the push rod to maintain a constant air gap and hence braking force. This actuator assembly is self contained in a rugged, cast aluminium housing which is designed for service in the harshest conditions. The whole unit mounts neatly onto one arm of the MX caliper. The EMX comes complete with a solid state controller, suitable for all normal AC supplies, and converts it to the required DC output to power and control the pancake motor. A 24vdc is also available.

The brake is released when the main power supply is to the controller is switched on, and reapplied when the power is disconnected. When the controller power supply is switched off, a controlled application of the brake occurs, electrically damped by utilising the motor back e.m.f. and a damping resistor.

The controller is contained in a strong steel wall mounted enclosure, protected to IP44 standard. A higher protection rating is available on request. Enclosure size 215mm x 215mm x 150mm deep. A range of standard discs are available from Twiflex, (see section 4).

Maximum braking force 6.1kN

[View Data Sheet](#)

▼ MXS - Self Adjusting

Spring applied – Pneumatically released

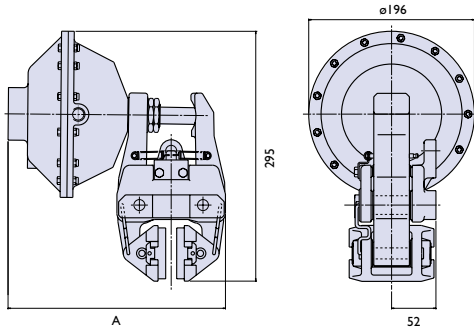

	A
XS 9.6	281
XS 7.5	270
XS 4.6	270

[View Data Sheet](#)

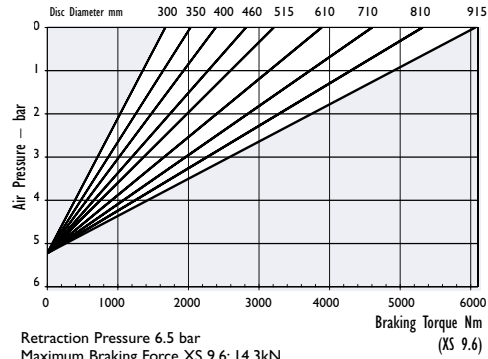

Retraction Pressure 6.5 bar
 Maximum Braking Force XS 9.6: 14.3kN
 Weight of caliper and thruster - 12kg
 Weight of thruster only - 5.5kg
 Volume displacement of thruster at full retraction = 1.19 l

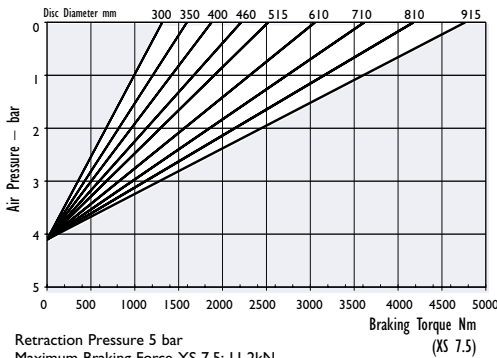

Retraction Pressure 5 bar
 Maximum Braking Force XS 7.5: 11.2kN
 Weight of caliper and thruster - 12kg
 Weight of thruster only - 5kg
 Volume displacement of thruster at full retraction = 1.19 l

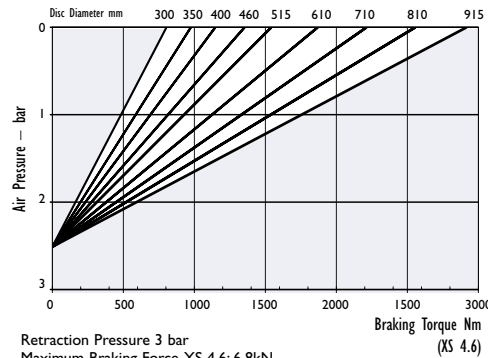

Retraction Pressure 3 bar
 Maximum Braking Force XS 4.6: 6.8kN
 Weight of caliper and thruster - 12kg
 Weight of thruster only - 5kg
 Volume displacement of thruster at full retraction = 1.19 l

MX

series



▼ MXSH - Self Adjusting

Spring applied – Hydraulically released

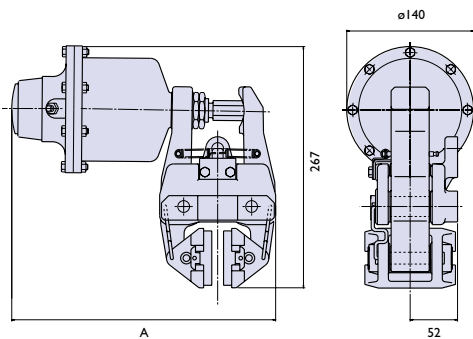

	A
XSH 9.6	315
XSH 7.5	290
XSH 4.6	290

[View Data Sheet](#)

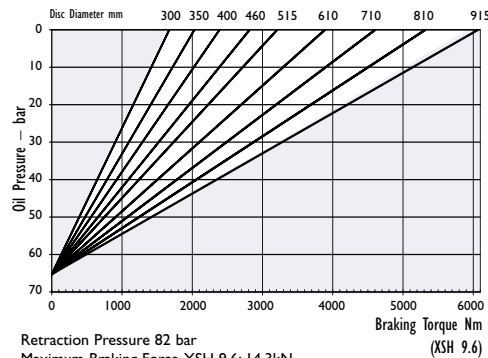

Retraction Pressure 82 bar
 Maximum Braking Force XSH 9.6: 14.3kN
 Weight of caliper and thruster - 11kg
 Weight of thruster only - 4.5kg
 Volume displacement of thruster at 6mm retraction = 9.1ml

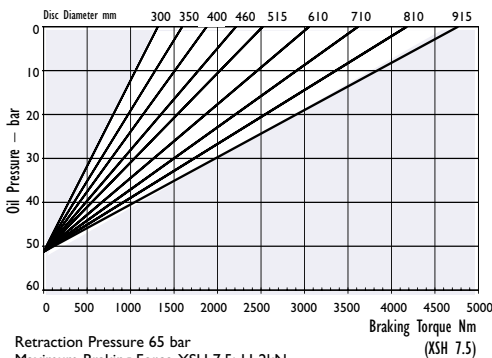

Retraction Pressure 65 bar
 Maximum Braking Force XSH 7.5: 11.2kN
 Weight of caliper and thruster - 11kg
 Weight of thruster only - 4kg
 Volume displacement of thruster at 6mm retraction = 9.1ml

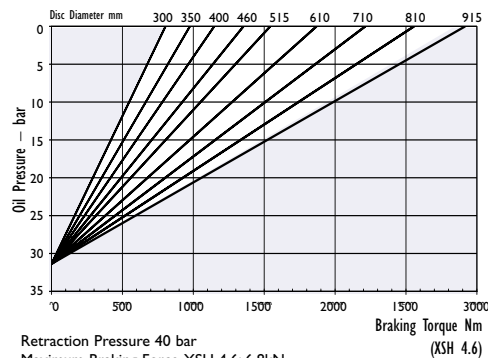

Retraction Pressure 40 bar
 Maximum Braking Force XSH 4.6: 6.8kN
 Weight of caliper and thruster - 11kg
 Weight of thruster only - 4kg
 Volume displacement of thruster at 6mm retraction = 9.1ml

3

Brake caliper range

▼ GMX Disc brake caliper

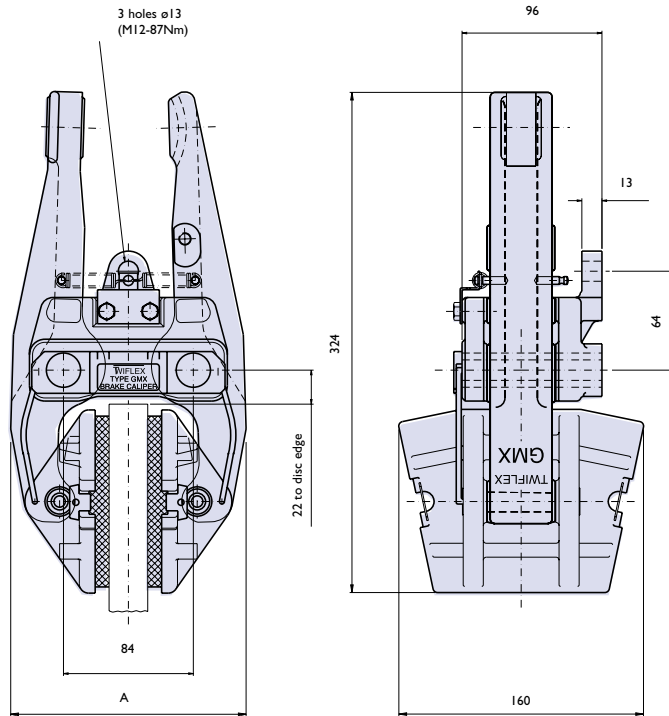

The Twiflex GMX25, GMX30 & GMX40 disc brake calipers are similar to the MX range of calipers, but with greater pad area.
The SGMX is used with a 25mm thick disc only.
Minimum Disc Diameter for the GMX Caliper is 610mm.

Effective Disc Radius = Actual Disc Radius (m) - 0.06m

	Disc Thickness	A
GMX 25	25	152
GMX 30	30	155
GMX 40	40	162

[View Data Sheet](#)

▼ SGMX Disc brake caliper

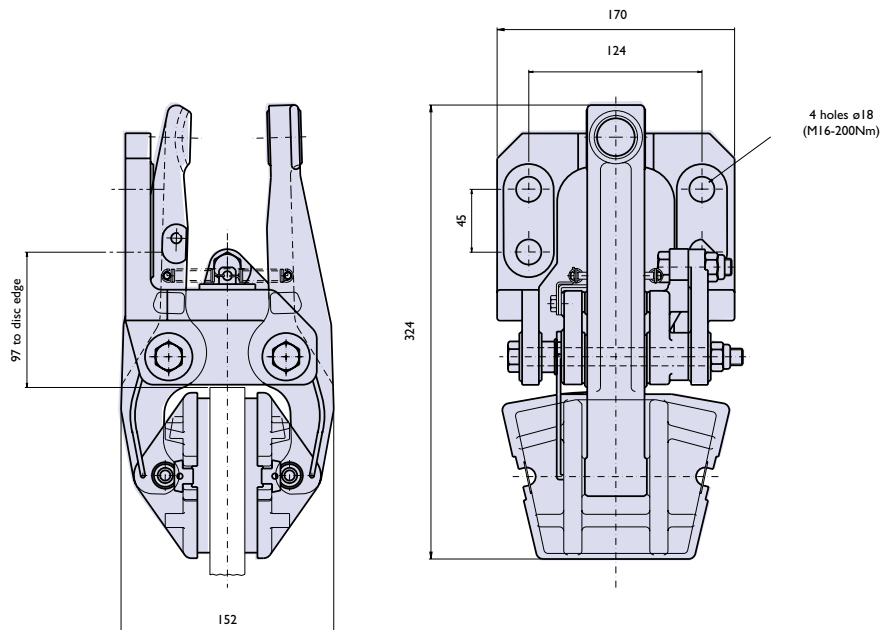

GMX
series



▼ GMXA

Pneumatically applied – Spring released

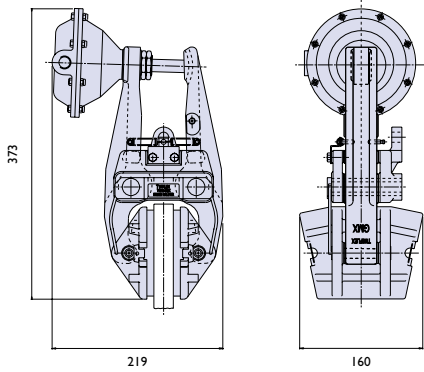

View Data Sheet

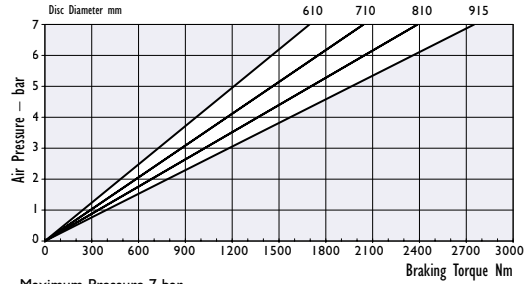

Maximum Pressure 7 bar
 Maximum Braking Force = 6.9kN @ 7 bar
 Weight of caliper and thruster - 10.57kg
 Weight of thruster only - 1.35kg
 Volume displacement of thruster at full stroke = 300ml

▼ GMXB

Pneumatically applied – Spring released

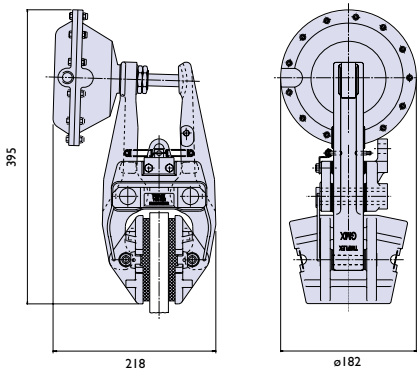

View Data Sheet

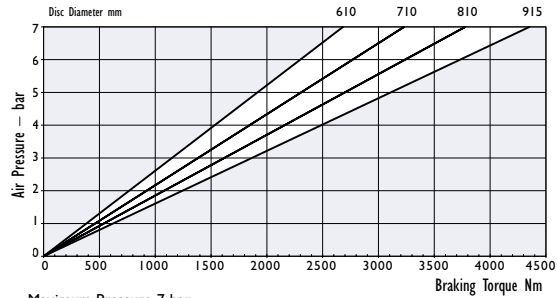

Maximum Pressure 7 bar
 Maximum Braking Force = 11kN @ 7 bar
 Weight of caliper and thruster - 11.28kg
 Weight of thruster only - 2.06kg
 Volume displacement of thruster at full stroke = 426ml

GMX
series



▼ GMXD

Pneumatically applied – Spring released

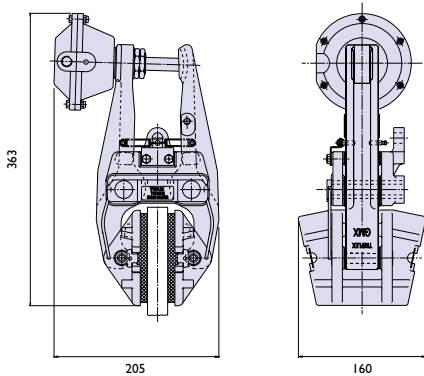

View Data Sheet

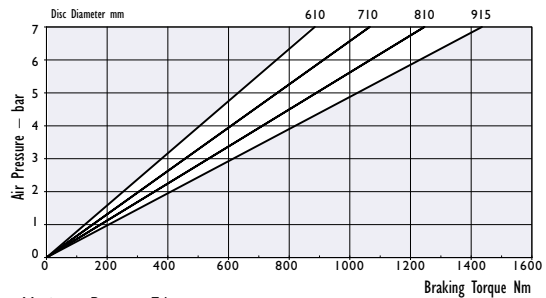

Maximum Pressure 7 bar
 Maximum Braking Force = 3.6kN @ 7 bar
 Weight of caliper and thruster - 10.34kg
 Weight of thruster only - 1.12kg
 Volume displacement of thruster at full stroke = 150ml

▼ GMXE

Pneumatically applied – Spring released

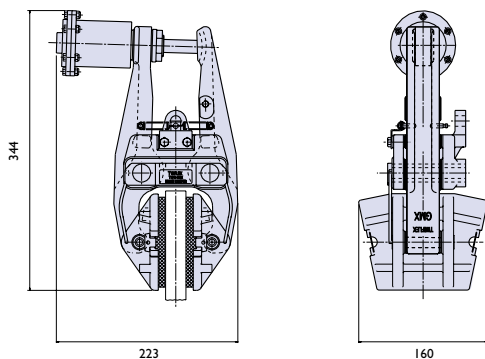

View Data Sheet

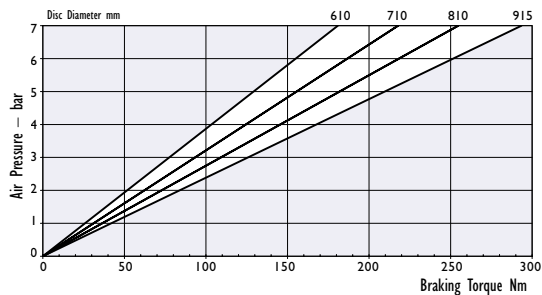

Maximum Pressure 7 bar
 Maximum Braking Force = 0.74kN @ 7 bar
 Weight of caliper and thruster - 9.56kg
 Weight of thruster only - 0.34kg
 Volume displacement of thruster at full stroke = 25ml

3

Brake caliper range

GMX
series



▼ GMXG

Pneumatically applied – Spring released

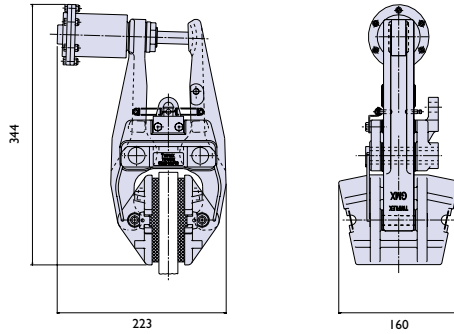

View Data Sheet

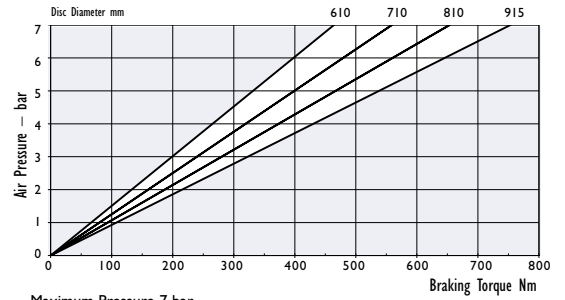

Maximum Pressure 7 bar
 Maximum Braking Force = 1.9kN @ 7 bar
 Weight of caliper and thruster - 9.52kg
 Weight of thruster only - 0.3kg
 Volume displacement of thruster at full stroke = 64ml

▼ GMXH

Mechanically applied – Lever operated

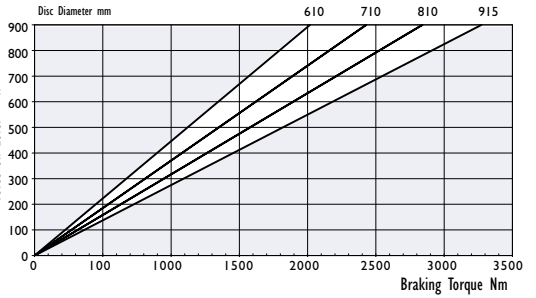
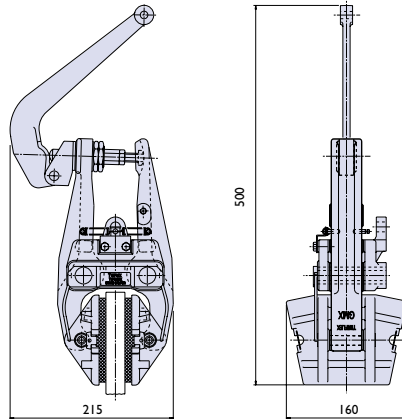

Weight of caliper and lever assembly - 10.62kg
 Weight of lever assembly only - 1.4kg
 Maximum Braking Force = 8.3kN @ 0.9kN force on lever

View Data Sheet

▼ GMXW

Mechanically applied – Hand operated

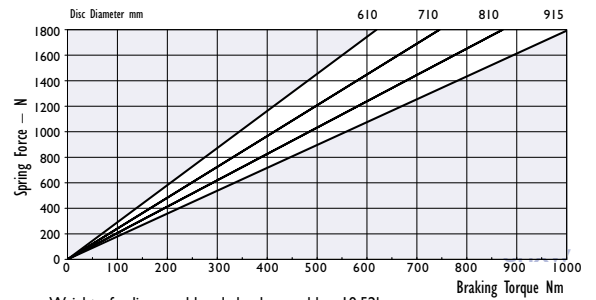
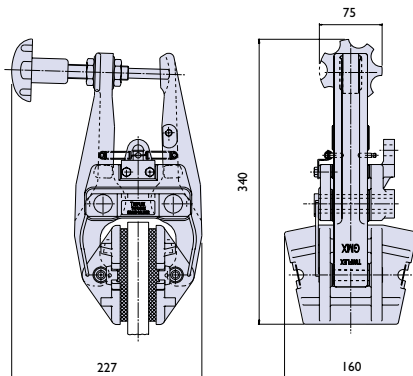

Weight of caliper and handwheel assembly - 10.52kg
 Weight of handwheel assembly only - 1.3kg
 Maximum Braking Force = 2.68kN

View Data Sheet

▼ GMXSE Spring Applied - Electromagnetically Released

The GMXSE is suitable for most medium to heavy duty holding and emergency stop applications. The design ensures long life, with fully potted coils protecting against harsh environments. A wide range of coil voltages is available, from 12VDC to 250VDC the standard units being 100VDC. The thruster contains two electromagnet coils. A release coil (high current) and a holding coil (low current). Power is simultaneously applied to both coils in order to release the brake. After 1-2 seconds the supply voltage to the release coil is removed. The holding coil remains energised, maintaining the brake in its released state. The brake units should ideally be mounted horizontally (in 3 or 9 o'clock positions) in relation to the disc. The use of an inclined mounting kit will allow the caliper to be mounted at an angle. The maximum angle the GMXSE should be mounted from the horizontal is 10°. A range of standard discs are available from Twiflex, (see section 4). Maximum braking force 5.2kN

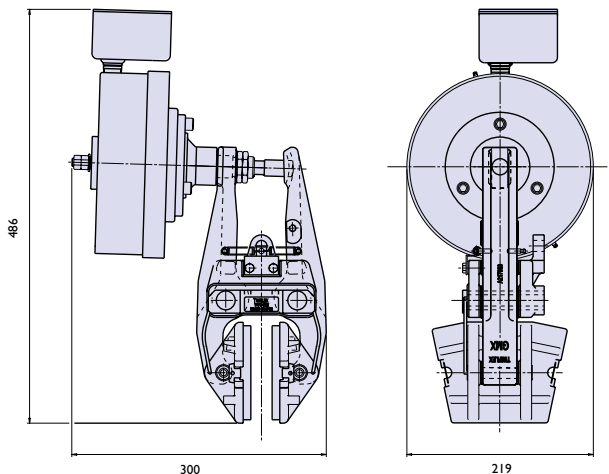

▼ EGMX - Self Adjusting Spring Applied - Electrically Released

The EGMX is a spring applied brake which is released by a ball screw mechanism. The drive is provided by a 175W pancake motor, which gives ample power whilst having a minimum space requirement. The actuator features a patented self adjusting mechanism. As the pads wear the mechanism adjusts the push rod to maintain a constant air gap and hence braking force. This actuator assembly is self contained in a rugged, cast aluminium housing which is designed for service in the harshest conditions. The whole unit mounts neatly onto one arm of the MX caliper. The EGMX comes complete with a solid state controller, suitable for all normal AC supplies, and converts it to the required DC output to power and control the pancake motor. A 24vdc version is also available. The brake is released when the main power supply is to the controller is switched on, and reapplied when the power is disconnected. When the controller power supply is switched off, a controlled application of the brake occurs, electrically damped by utilising the motor back e.m.f. and a damping resistor. The controller is contained in a strong steel wall mounted enclosure, protected to IP44 standard. A higher protection rating is available on request. Enclosure size 215mm x 215mm x 150mm deep. A range of standard discs are available from Twiflex, (see section 4). Maximum braking force 6.1kN

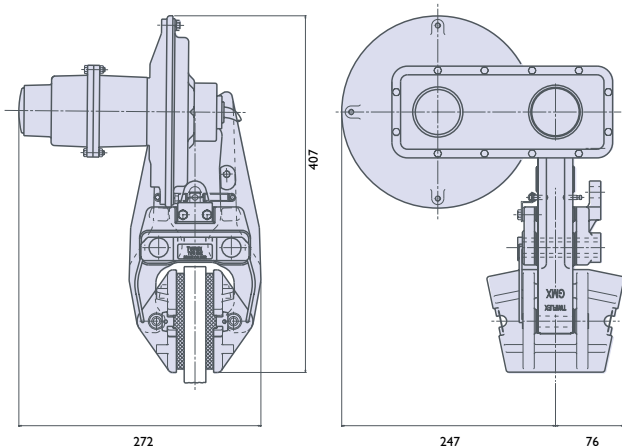

GMX
series



▼ GMXS - Self Adjusting

Spring applied – Pneumatically released

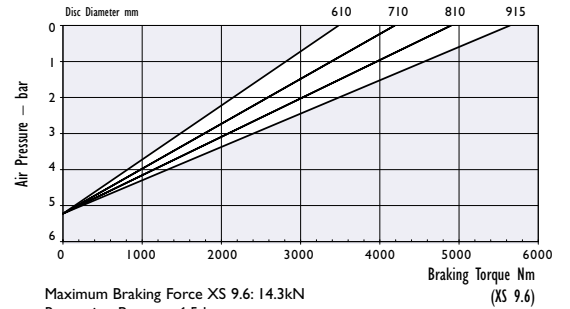
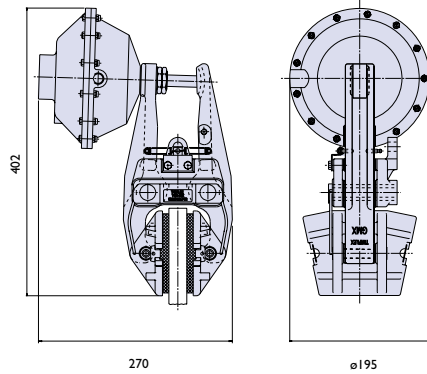

Maximum Braking Force XS 9.6: 14.3kN
Retraction Pressure 6.5 bar
Weight of caliper and thruster - 14.22kg
Weight of thruster only - 5.1kg
Volume displacement of thruster at full retraction = 1.19 l

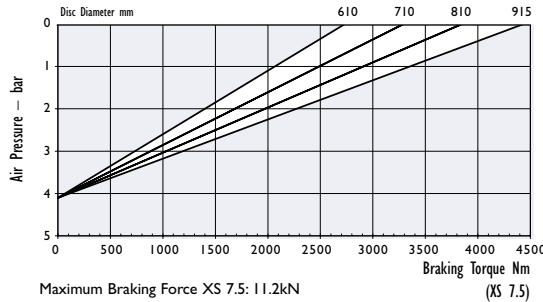

Maximum Braking Force XS 7.5: 11.2kN
Retraction Pressure 5 bar
Weight of caliper and thruster - 14.22kg
Weight of thruster only - 4.9kg
Volume displacement of thruster at full retraction = 1.19 l

[View Data Sheet](#)

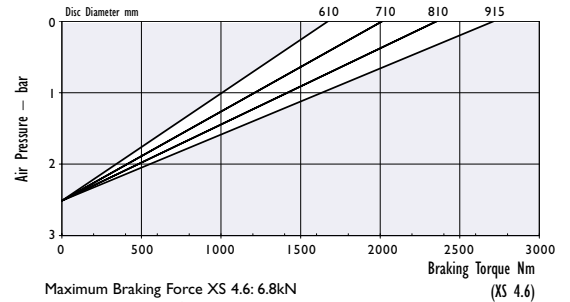

Maximum Braking Force XS 4.6: 6.8kN
Retraction Pressure 3 bar
Weight of caliper and thruster - 14.22kg
Weight of thruster only - 4.5kg
Volume displacement of thruster at full retraction = 1.19 l

GMX
series



▼ GMXSH - Self Adjusting

Spring applied – Hydraulically released

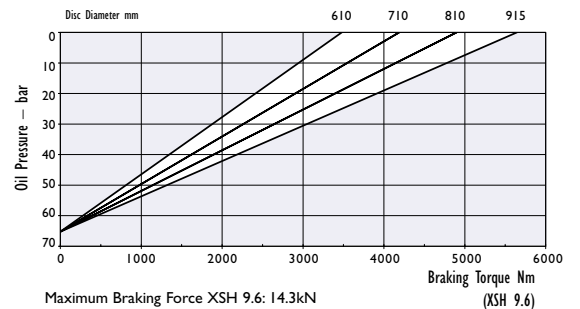
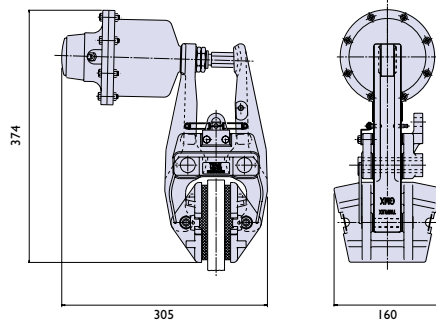

Maximum Braking Force XSH 9.6: 14.3kN
Retraction Pressure 82 bar
Weight of caliper and thruster - 13.22kg
Weight of thruster only - 4.6kg
Volume displacement of thruster at 4mm retraction = 9.1ml

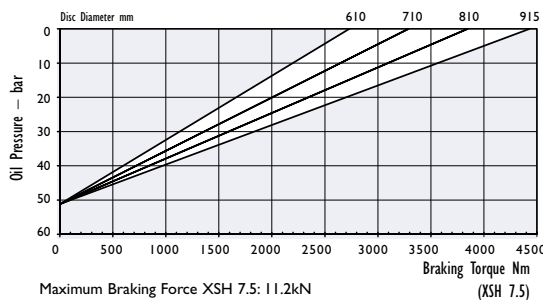

Maximum Braking Force XSH 7.5: 11.2kN
Retraction Pressure 63 bar
Weight of caliper and thruster - 13.22kg
Weight of thruster only - 4.4kg
Volume displacement of thruster at 4mm retraction = 9.1ml

[View Data Sheet](#)

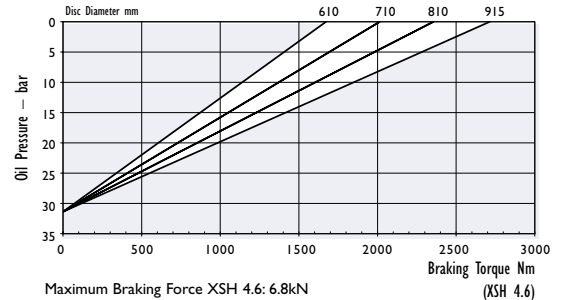

Maximum Braking Force XSH 4.6: 6.8kN
Retraction Pressure 40 bar
Weight of caliper and thruster - 13.22kg
Weight of thruster only - 4kg
Volume displacement of thruster at 4mm retraction = 9.1ml

▼ GMR Disc brake caliper

The Twiflex GMR & GMR40 disc brake calipers are used with brake discs of 25mm and 40mm thick, respectively. They may be used with a number of the Twiflex series of actuators.

The range of pneumatically operated brakes, use dry and filtered compressed air at pressures up to 7 bar.

Pneumatic brakes require a control valve, which may be operated either manually, or by pneumatic or electrical signal.

Normally one or two brakes will be used per disc, but the number may be increased, depending on disc size. The brake units can be positioned at any angle around the periphery of the disc, but ideally they should be mounted horizontally (in 3 or 9 o'clock positions) in relation to the disc.

If a caliper is mounted on an inclined surface it should be fitted with an inclined mounting kit. This applies also to calipers used on vertical shaft installations.

A range of standard discs is available from Twiflex, (see section 4). Minimum disc diameter for the GMR caliper is 610mm.

The ratings shown on the graphs are based on fully bedded and conditioned brake pads with nominal friction coefficient $\mu = 0.4$.

Twiflex disc brakes must be used with Twiflex asbestos free brake pads.

Effective Disc Radius = Actual Disc Radius (m) - 0.06m

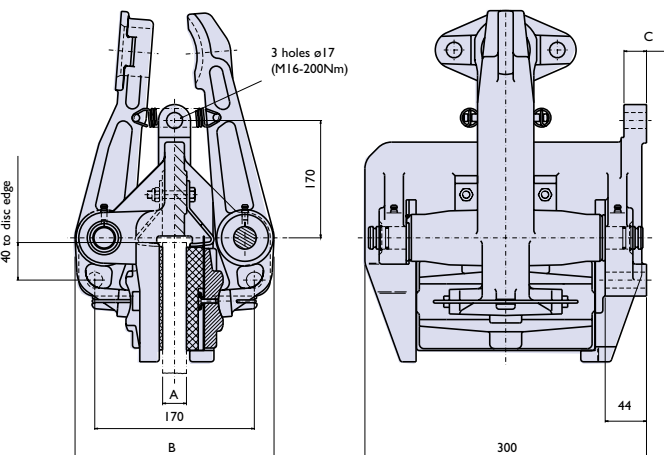

	A	B	C
GMR 25	25	212	24
GMR 30	40	223	29

View Data Sheet

GMR

series



▼ GMRP

Pneumatically applied – Spring released

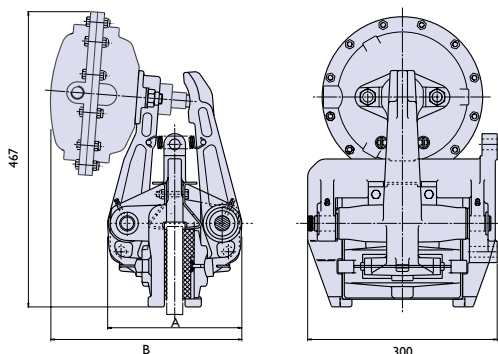

	A	B
GMR P	212	306
GMR40 P	223	312

View Data Sheet

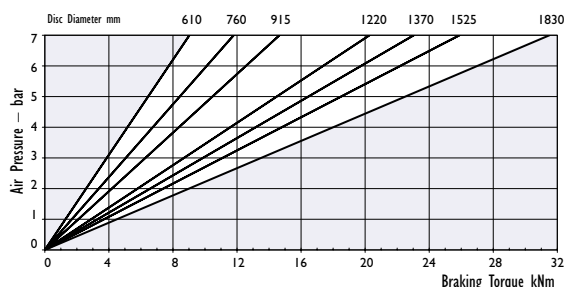

Maximum Pressure 7 bar
 Maximum Braking Force = 36kN @ 7 bar
 Weight of caliper and thruster - 40.8kg
 Weight of thruster only - 6.8kg
 Volume displacement of thruster at full stroke = 1.8 l

▼ GMRH

Hydraulically applied – Spring released

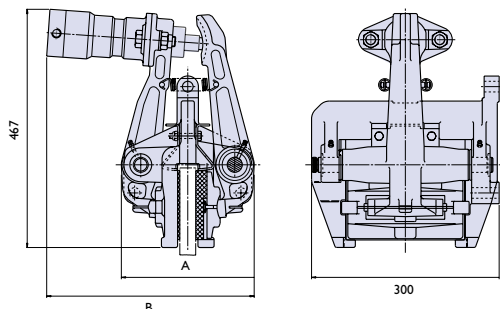

	A	B
GMR H	212	332
GMR40 H	223	343

View Data Sheet

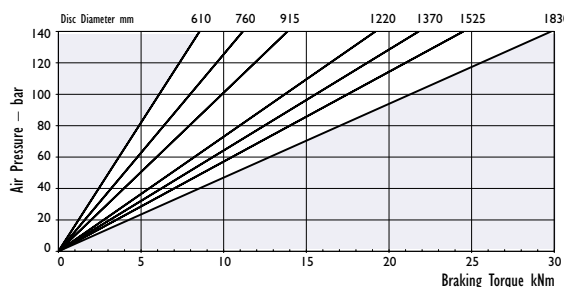

Maximum Pressure 140 bar
 Maximum Braking Force = 36kN @ 140 bar
 Weight of caliper and thruster - 36.9kg
 Weight of thruster only - 2.9kg
 Volume displacement of thruster at full stroke = 40ml

▼ GMR S Disc brake caliper

Spring applied – Pneumatically released

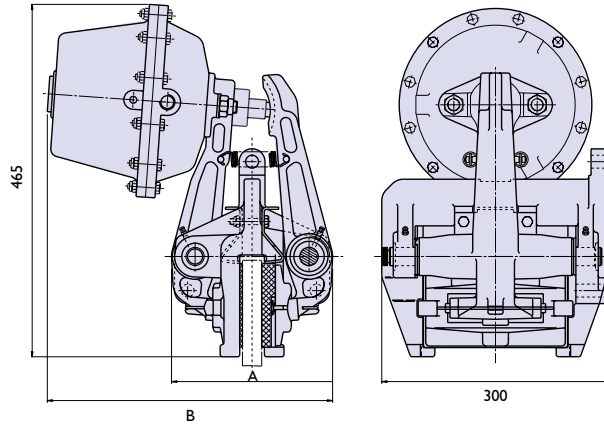

	A	B
GMR S	212	376
GMR40 S	223	382

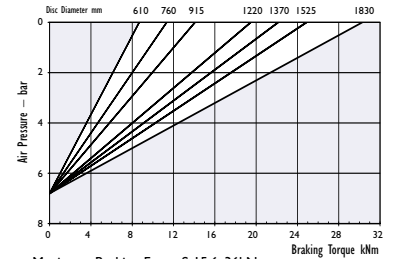

Maximum Braking Force S 15.6: 36kN
Retraction Pressure 8.4 bar
Weight of caliper and thruster - 49kg
Weight of thruster only - 15kg
Volume displacement of thruster at full retraction = 1.3 l

View Data Sheet

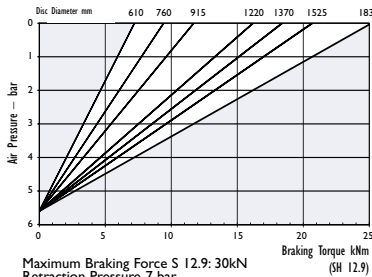

Maximum Braking Force S 12.9: 30kN
Retraction Pressure 7 bar
Weight of caliper and thruster - 48kg
Weight of thruster only - 14kg
Volume displacement of thruster at full retraction = 1.3 l

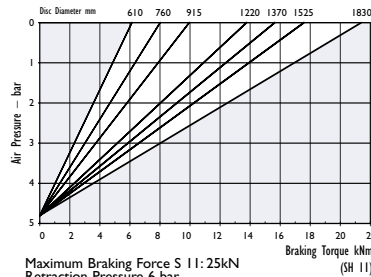

Maximum Braking Force S 11: 25kN
Retraction Pressure 6 bar
Weight of caliper and thruster - 47.2kg
Weight of thruster only - 13.2kg
Volume displacement of thruster at full retraction = 1.3 l

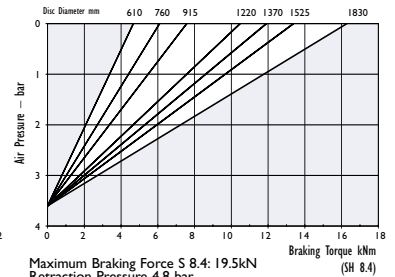

Maximum Braking Force S 8.4: 19.5kN
Retraction Pressure 4.8 bar
Weight of caliper and thruster - 46.2kg
Weight of thruster only - 12.2kg
Volume displacement of thruster at full retraction = 1.3 l

GMR series



▼ GMRSD Disc brake caliper

Spring applied – Pneumatically released

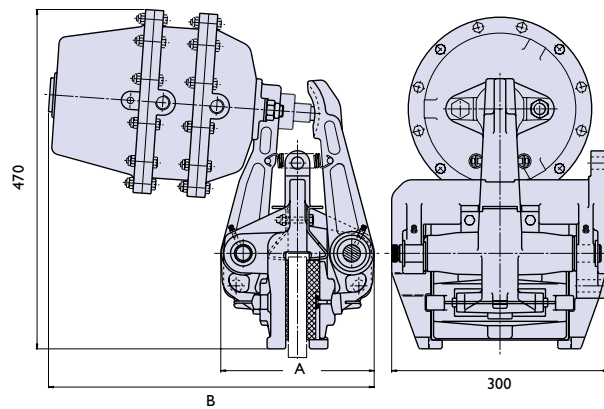

	A	B
GMR SD	212	451
GMR40 SD	223	457

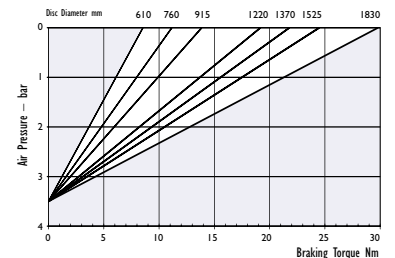

Maximum Braking Force SD 15.6: 36kN
Retraction Pressure 4.6 bar
Weight of caliper and thruster - 55kg
Weight of thruster only - 21kg
Volume displacement of thruster at full retraction = 2.5 l

View Data Sheet

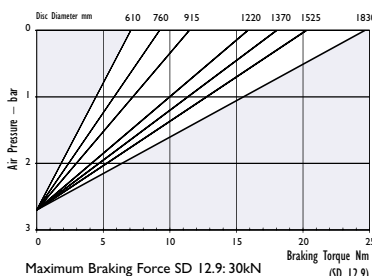

Maximum Braking Force SD 12.9: 30kN
Retraction Pressure 3.8 bar
Weight of caliper and thruster - 54kg
Weight of thruster only - 20kg
Volume displacement of thruster at full retraction = 2.5 l

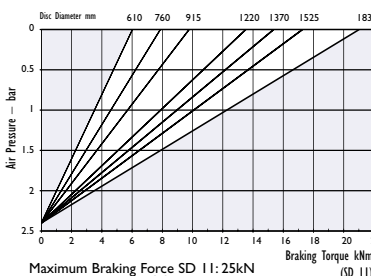

Maximum Braking Force SD 11: 25kN
Retraction Pressure 3.3 bar
Weight of caliper and thruster - 53.2kg
Weight of thruster only - 19.2kg
Volume displacement of thruster at full retraction = 2.5 l

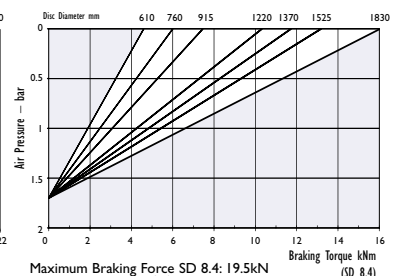

Maximum Braking Force SD 8.4: 19.5kN
Retraction Pressure 2.4 bar
Weight of caliper and thruster - 52.2kg
Weight of thruster only - 18.2kg
Volume displacement of thruster at full retraction = 2.5 l

▼ GMRSH Spring applied – Hydraulically released

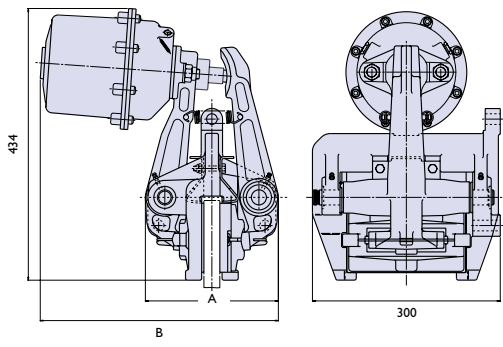

	A	B
GMR SH	212	380
GMR40 SH	223	387

View Data Sheet

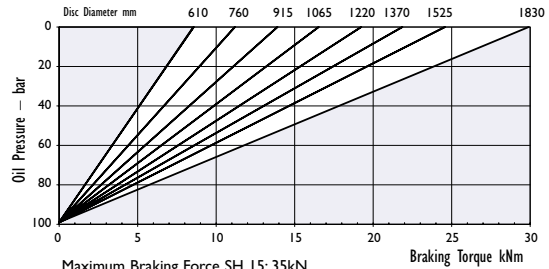

Maximum Braking Force SH 15: 35kN
 Retraction Pressure 120 bar
 Weight of caliper and thruster - 53kg
 Weight of thruster only - 19kg
 Volume displacement of thruster at full retraction = 56ml

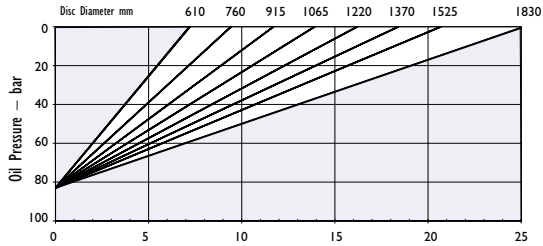

Maximum Braking Force SH 12.9: 30kN
 Retraction Pressure 100 bar
 Weight of caliper and thruster - 52kg
 Weight of thruster only - 18kg
 Volume displacement of thruster at full retraction = 56ml

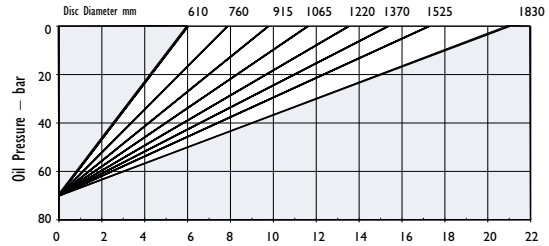

Maximum Braking Force SH 11: 25kN
 Retraction Pressure 92 bar
 Weight of caliper and thruster - 51.2kg
 Weight of thruster only - 17.2kg
 Volume displacement of thruster at full retraction = 56ml

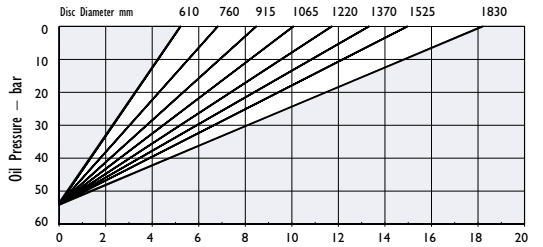

Maximum Braking Force SH 8.4: 19.5kN
 Retraction Pressure 65 bar
 Weight of caliper and thruster - 50.2kg
 Weight of thruster only - 16.2kg
 Volume displacement of thruster at full retraction = 56ml

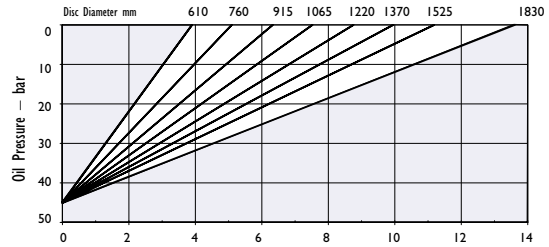

Maximum Braking Force SH 7: 16.5kN
 Retraction Pressure 59 bar
 Weight of caliper and thruster - 49.7kg
 Weight of thruster only - 15.7kg
 Volume displacement of thruster at full retraction = 56ml

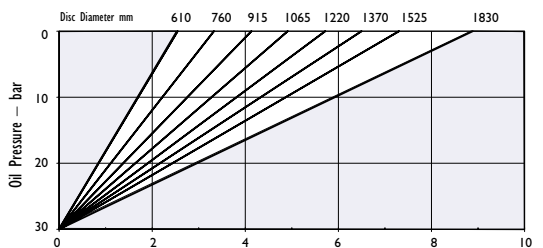

Maximum Braking Force SH 4.5: 10.5kN
 Retraction Pressure 38 bar
 Weight of caliper and thruster - 48.7kg
 Weight of thruster only - 14.7kg
 Volume displacement of thruster at full retraction = 56ml

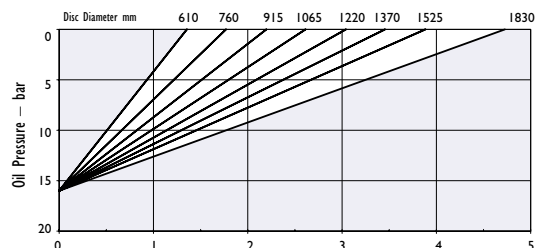

Maximum Braking Force SH 2.5: 6kN
 Retraction Pressure 21 bar
 Weight of caliper and thruster - 47.9kg
 Weight of thruster only - 13.9kg
 Volume displacement of thruster at full retraction = 56ml

GMR series





▼ CE2

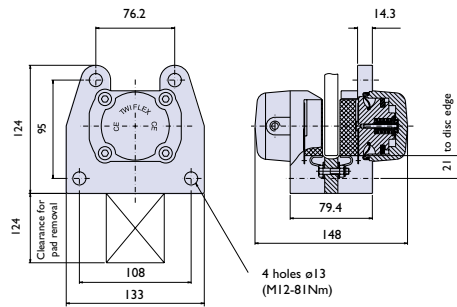

The Twiflex CE2 disc brake caliper is used with a brake disc of 12.7mm thick.

Normally one or two brakes will be used per disc, but the number may be increased, depending on disc size. The brake units can be positioned at any angle around the periphery of the disc.

A range of standard discs of 12.7mm thickness is available from Twiflex, (see section 4).

Minimum disc diameter for the CE2 caliper is 300mm.

The ratings shown on the graph are based on fully bedded and conditioned brake pads with nominal friction coefficient $\mu = 0.4$. Twiflex Disc Brakes must be used with Twiflex asbestos free brake pads.

Effective Disc Radius = Actual Disc Radius (m) - 0.03m

Hydraulically applied

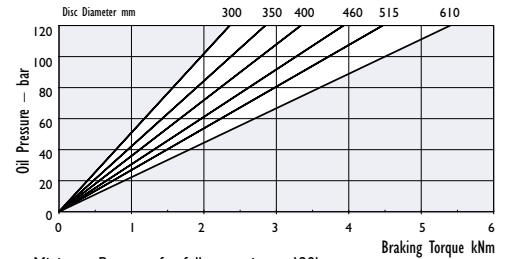

Minimum Pressure for full retraction = 120bar
 Maximum Braking Force = 19.6kN @ 120 bar
 Weight of caliper - 6.5kg
 Volume displacement per 1mm stroke = 4.8ml

▼ TS16

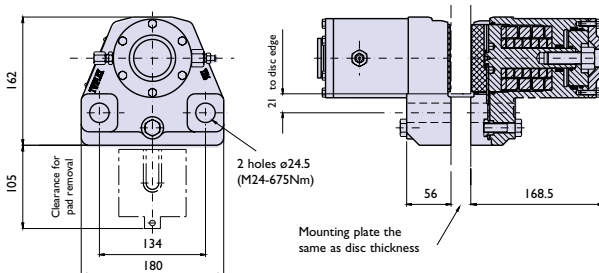

The Twiflex TS16 disc brake caliper is a split caliper design comprising two similar halves or spring modules and is used with a brake disc thickness from 20mm and over. The caliper is mounted on a central mounting plate of the same thickness as the brake disc, the mounting plate being sandwiched between the caliper halves. Normally one or two brakes will be used per disc, but the number may be increased, depending on disc size. The brake units can be positioned at any angle around the periphery of the disc. A range of standard discs is available from Twiflex, (see section 4). Minimum disc diameter for the TS16 caliper is 300mm.

The ratings shown on the graph are based on fully bedded and conditioned brake pads with nominal friction coefficient $\mu = 0.4$. Twiflex Disc Brakes must be used with Twiflex asbestos free brake pads.

Effective Disc Radius = Actual Disc Radius (m) - 0.045m

Spring applied – Hydraulically released

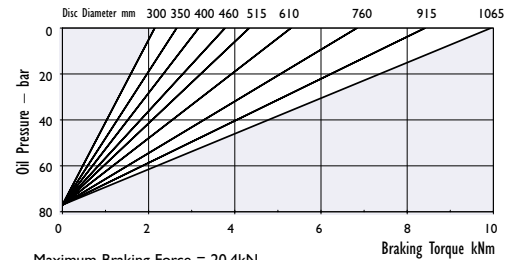

Maximum Braking Force = 20.4kN
 Retraction Pressure 80 bar
 Weight of caliper - 21kg
 Volume displacement per 1mm stroke = 6.7ml

▼ T2 Disc brake caliper

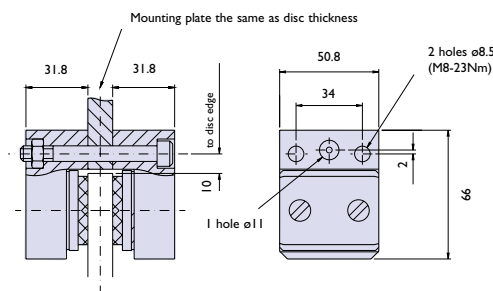

The Twiflex T2 disc brake caliper is a split caliper design and is adaptable for use on a wide range of brake disc thickness from 5mm.

The caliper is normally mounted on a central mounting plate of the same thickness as the brake disc, the mounting plate being sandwiched between the caliper halves. Alternatively, the caliper may be secured to a side mounting plate with a spacer of the same thickness as the disc between the two halves. For pneumatically operated brakes, use dry and filtered compressed air. Pneumatic brakes require a control valve, which may be operated either manually, or by pneumatic or electrical signal. Normally one or two brakes will be used per disc, but the number may be increased, depending on disc size. The brake units can be positioned at any angle around the periphery of the disc. A range of standard discs is available from Twiflex, (see section 4). Minimum disc diameter for the T2 caliper is 120mm.

The ratings shown on the graph are based on fully bedded and conditioned brake pads with nominal friction coefficient $\mu = 0.4$. Twiflex Disc Brakes must be used with Twiflex asbestos free brake pads.

Effective Disc Radius = Actual Disc Radius (m) - 0.019m

Pneumatically or Hydraulically applied

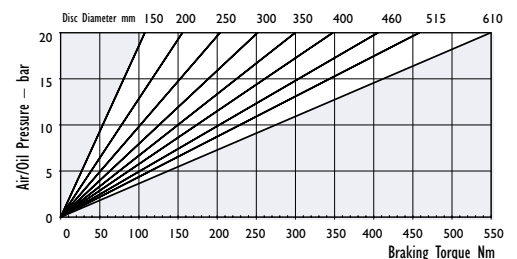

Maximum Pressure 20 bar
 Maximum Braking Force = 2kN @ 20 bar oil or air pressure
 Weight of caliper - 0.75kg
 Volume displacement per 1mm stroke = 3ml

▼ T20

Hydraulically applied

The Twiflex T20 disc brake caliper is a split caliper design and is adaptable for use on a wide range of brake disc thickness from 8mm. The caliper is normally cantilever mounted from a side plate. For use with a brake disc thickness greater than 12.7mm the split design of the caliper allows a spacer plate to be sandwiched between the caliper halves. The spacer plate may also serve as the mounting plate when the caliper is used with discs of 20mm thickness and upwards. Normally one or two brakes will be used per disc, depending on disc size. The brake units can be positioned at any angle around the periphery of the disc. A range of standard discs is available from Twiflex, (see section 4).

Minimum disc diameter for the T20 caliper is 300mm.
 The ratings shown on the graph are based on fully bedded and conditioned brake pads with nominal friction coefficient $\mu = 0.4$.
 Twiflex Disc Brakes must be used with Twiflex asbestos free brake pads.
 Effective Disc Radius = Actual Disc Radius (m) - 0.032m

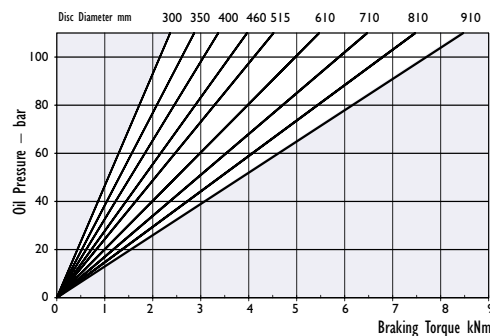
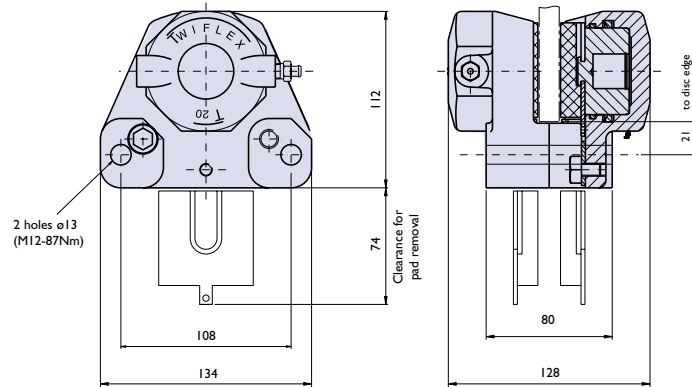

Maximum Pressure 110 bar
 Maximum Braking Force = 20kN @ 110 bar
 Weight of caliper - 5.82kg
 Volume displacement per 1mm stroke = 4.8ml

modular series



▼ T40

Hydraulically applied

The Twiflex T40 disc brake caliper is a split caliper design and is adaptable for use on a wide range of brake disc thickness from 20mm. The caliper is mounted on a central mounting plate of the same thickness as the brake disc, the mounting plate being sandwiched between the caliper halves. Normally one or two brakes will be used per disc, but the number may be increased, depending on disc size. The brake units can be positioned at any angle around the periphery of the disc. A range of standard discs is available from Twiflex, (see section 4).

Minimum disc diameter for the T40 caliper is 300mm.
 The ratings shown on the graph are based on fully bedded and conditioned brake pads with nominal friction coefficient $\mu = 0.4$.
 Twiflex Disc Brakes must be used with Twiflex asbestos free brake pads.
 Effective Disc Radius = Actual Disc Radius (m) - 0.045m

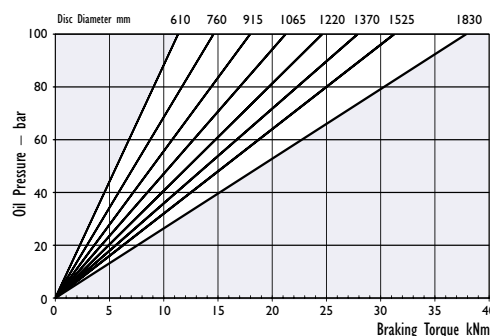
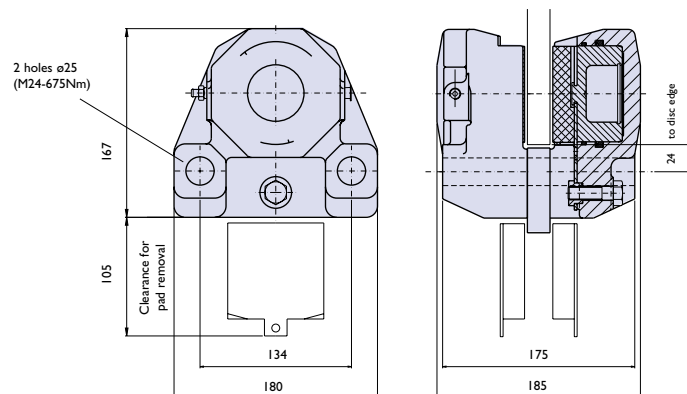

Maximum Pressure 100 bar
 Maximum Braking Force = 45kN @ 100 bar
 Weight of caliper - 18.6kg
 Volume displacement per 1mm stroke = 15ml



▼ VCS Mk3

Spring applied – Hydraulically released

The Twiflex VCS disc brake caliper comprises of two similar halves or hydraulic modules and is used with a brake disc thickness from 20mm. The caliper modules are mounted each side of a central mounting plate of the same thickness as the brake disc.

Each module has a variable number of disc springs to produce a braking force in the range of 14kN up to 60kN. Braking force is also dependent on the pad/disc air gap.

Normally one or two brakes will be used per disc, but the number may be increased, depending on disc size. The brake units can be positioned at any angle around the periphery of the disc.

A range of Brake Discs is available from Twiflex. Minimum disc diameter for the VCS caliper is 500mm. Twiflex Disc Brakes must be used with Twiflex asbestos free brake pads.

Contact Twiflex for installation details.

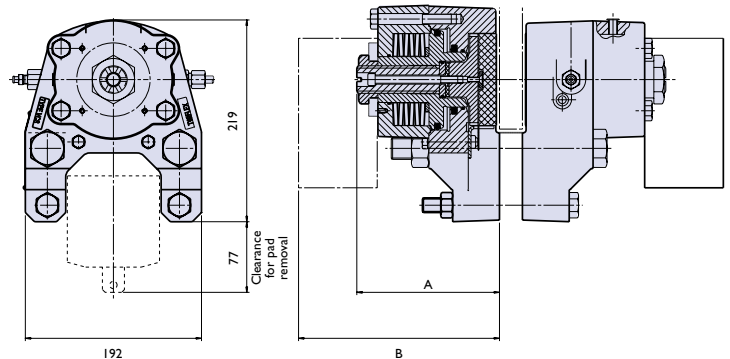

	A	B
Long	184	247
Standard	152	215

Caliper Type	Disc/Pad Air Gap mm	Braking Force kN	Hydraulic Pressure for Full Retraction bar
VCS72L	2	62	162
VCS60L	2	50	138
VCS55L	2.5	43	106
VCS50L	2.5	37	94
VCS40L	3.5	30	77
VCS40S	2	31	77
VCS25S	3.5	20	54
VCS22S	3.5	14	44

Maximum Retraction Pressure 162 bar

Weight of caliper (2 modules) - 46kg

Volume displacement per 1mm stroke at both pads = 14ml

▼ VCS -FL

A version of this brake, known as the VCS-FL, is available for use where space is limited and when the brake disc has excessive lateral movement. Only one brake module is used with a reactive pad plate.

Contact Twiflex for installation details.

Note:

Spring fatigue life is a function of the caliper rating.

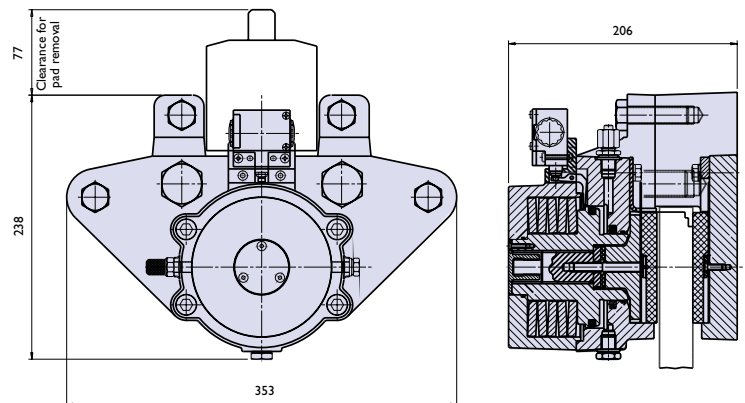

The ratings shown in the table are based on fully bedded and conditioned brake pads with nominal friction coefficient $\mu = 0.4$.

Braking Torque (kNm) = Braking Force (kN) x Effective Disc Radius (m)

Where Effective Disc Radius (m) = Actual Disc Radius - 0.054m

▼ VKSD

Spring applied – Hydraulically released

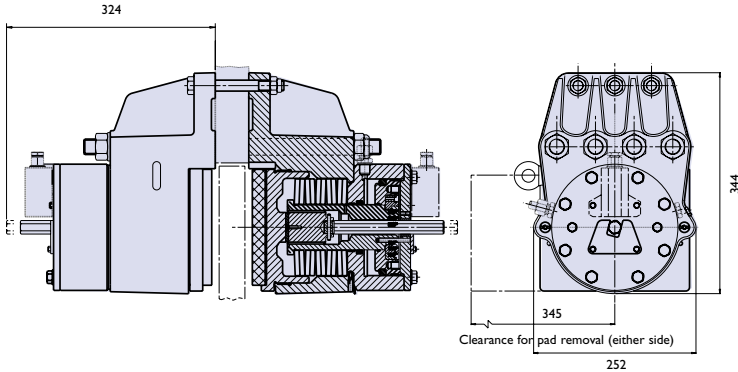

The Twiflex VKSD disc brake caliper comprises of two similar halves or hydraulic modules and is used with a brake disc thickness from 20mm. The caliper modules are mounted each side of a central mounting plate of 12mm greater thickness than the brake disc. Braking forces of between 28kN – 119kN can be achieved through a combination of different springs, shims and air gap settings.

Normally one or two brakes will be used per disc, but the number may be increased, depending on disc size. The brake units can be positioned at any angle around the periphery of the disc, but ideally they should be mounted horizontally (3 or 9 o'clock positions). A range of Brake Discs is available from Twiflex. Minimum disc diameter for the VKSD caliper is 1000mm.

The ratings shown on the graph are based on fully bedded and conditioned brake pads with nominal friction coefficient $\mu = 0.4$. Twiflex Disc Brakes must be used with Twiflex asbestos free brake pads. *Contact Twiflex for installation details.*

modular series



Caliper Type	Disc/Pad Air Gap mm	Braking Force kN	Hydraulic Pressure for Full Retraction bar
VKSD119	2	119	138
VKSD112	2	112	131
VKSD104	2	104	124
VKSD96	2	96	116
VKSD88	2	88	108
VKSD80	2	80	100
VKSD71	2	71	92
VKSD62	2	62	83
VKSD58	2	58	63
VKSD53	2	53	58
VKSD47	2	47	53
VKSD41	2	41	47
VKSD34	2	34	41
VKSD28	2	28	34

Weight of caliper (2 modules) - 146kg
Volume displacement per 1mm stroke at both pads = 28ml

▼ VKSD-FL

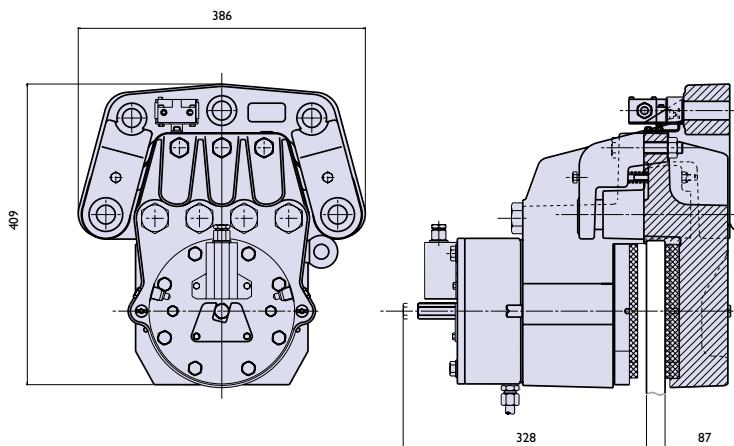

A version of this brake, known as the VKSD-FL, is available for use where space is limited and when the brake disc has excessive lateral movement. Only one brake module is used with a reactive pad plate. *Contact Twiflex for installation details.*

Note:
Spring fatigue life is a function of the caliper rating.

The ratings shown in the table are based on fully bedded and conditioned brake pads with nominal friction coefficient $\mu = 0.4$.
Braking Torque (kNm) = Braking Force (kN) x Effective Disc Radius (m)
Where Effective Disc Radius (m) = Actual Disc Radius - 0.095m



▼ VKHD

Hydraulically applied – Spring released

The Twiflex VKHD disc brake caliper comprises of two similar halves or hydraulic modules and is used with a brake disc thickness from 20mm. The caliper modules are mounted each side of a central mounting plate of 12mm greater thickness than the brake disc. Normally one or two brakes will be used per disc, but the number may be increased, depending on disc size. The brake units can be positioned at any angle around the periphery of the disc. A range of Brake Discs is available from Twiflex.

Minimum disc diameter for the VKHD caliper is 1000mm.

The ratings shown on the graph are based on fully bedded and conditioned brake pads with nominal friction coefficient $\mu = 0.4$.

Twiflex Disc Brakes must be used with Twiflex asbestos free brake pads.

Effective Disc Radius = Actual Disc Radius (m) - 0.095m

Contact Twiflex for installation details.

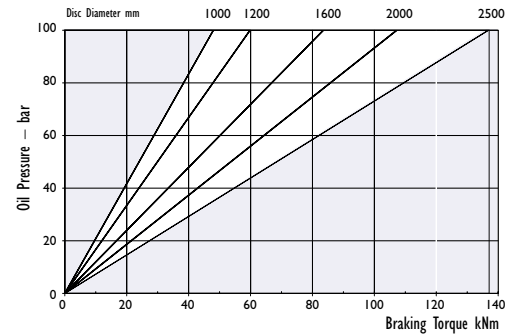
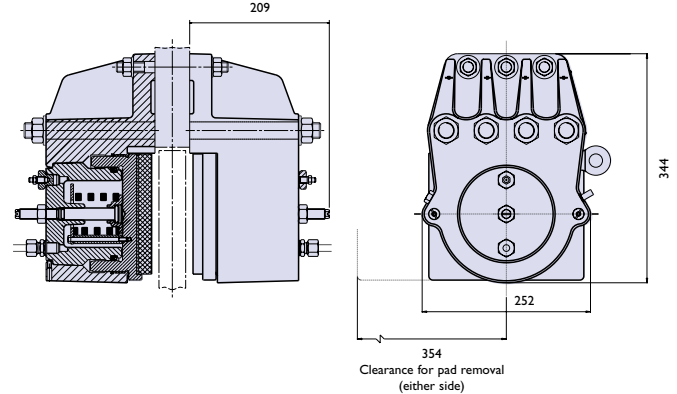

Maximum Pressure 100 bar
 Maximum Braking Force = 118kN @ 100 bar
 Weight of caliper (2 modules) - 80kg
 Volume displacement per 1mm stroke at both pads = 31ml

▼ VS Mk2

Spring applied – Hydraulically released

The Twiflex VS disc brake caliper is comprised of two modules secured to U-shaped top and bottom mounting plates by means of tie rods.

Normally one or two brakes will be used per disc, but the number may be increased, depending on disc size. The brake units can be positioned at any angle around the periphery of horizontal or vertical brake discs, but ideally they should be mounted horizontally (in 3 or 9 o'clock positions).

A range of discs is available from Twiflex.

Minimum disc diameter for the VS caliper is 1000mm.

For tandem calipers (two calipers mounted one on top of the other), the minimum disc diameter is 2 metres.

Disc thickness from 38mm.

Twiflex Disc Brakes must be used with Twiflex asbestos free brake pads.

Maximum Braking Force: 185kN

Retraction Pressure 180 bar

Weight of caliper - 410kg

Volume displacement per 1mm stroke at both pads = 32ml

Contact Twiflex for installation details.

Note:

Spring fatigue life is a function of the caliper rating.

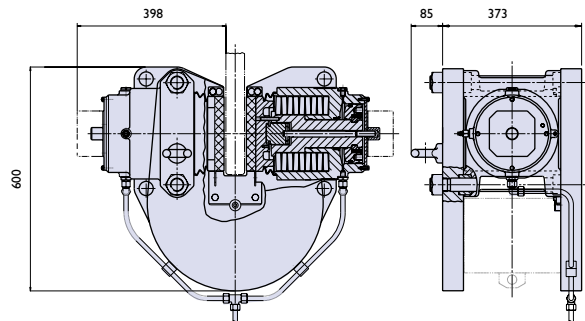

Caliper Type	Disc/Pad Air Gap mm	Braking Force kN	Hydraulic Pressure for Full Retraction bar
VS230	4	185	180
VS205	4	165	163
VS190	4	153	154
VS175	4	141	144
VS155	4	125	131
VS137	4	111	108
VS100	4	81	84

The ratings shown in the table are based on fully bedded and conditioned brake pads with nominal friction coefficient $\mu = 0.4$.

Braking Torque (kNm) = Braking Force (kN) x Effective Disc Radius (m)
 Where Effective Disc Radius (m) = Actual Disc Radius - 0.110m

▼ VH

Hydraulically applied – Spring released

The Twiflex VH disc brake caliper is comprised of two separate one-piece cylinder housing modules located between a U-shaped top plate and a base mounting plate and is normally used with a brake disc thickness of 50mm. Normally one or two brakes will be used per disc, but the number may be increased, depending on disc size. The brake units can be positioned at any angle around the periphery of the disc, but ideally they should be mounted horizontally (in 3 or 9 o'clock positions) in relation to the disc.

A range of brake discs is available from Twiflex, (see section 4).

Minimum disc diameter for the VH caliper is 1000mm.

The ratings shown on the graph are based on fully bedded and conditioned brake pads with nominal friction coefficient $\mu = 0.4$.

Twiflex Disc Brakes must be used with Twiflex asbestos free brake pads.

Effective disc radius =
Actual disc radius (m) - 0.11m
Contact Twiflex for installation details.

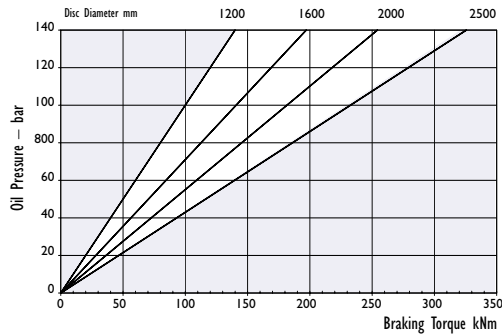
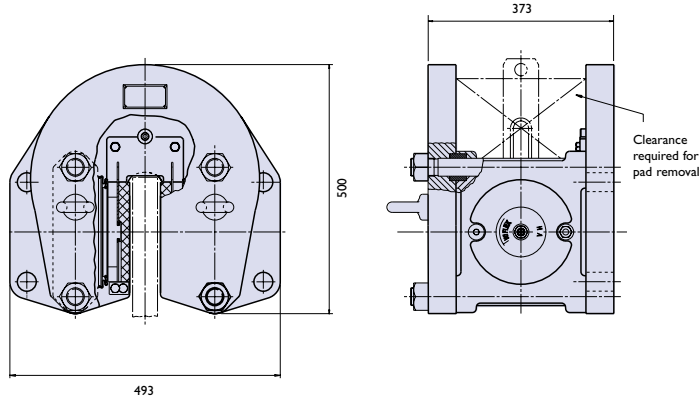

Maximum Pressure 140 bar
Maximum Braking Force = 285kN @ 140 bar
Weight of caliper - 287kg
Volume displacement per 1mm stroke at both pads = 51.7ml

modular series



▼ VMH2

Hydraulically applied – Spring released

The Twiflex VMH2 disc brake caliper is comprised of two modules secured to a centrally located mounting plate by means of rods and bolts and is used with a brake disc thickness of 38mm and over. The central mounting plate thickness is 12mm greater than the brake disc.

Normally one or two brakes will be used per disc, but the number may be increased, depending on disc size. The brake units can be positioned at any angle around the periphery of the disc. A range of brake discs is available from Twiflex, (see section 4).

Minimum disc diameter for the VMH2 caliper is 1500mm.

The ratings shown on the graph are based on fully bedded and conditioned brake pads with nominal friction coefficient $\mu = 0.4$.

Twiflex Disc Brakes must be used with Twiflex asbestos free brake pads.

Effective disc radius =
Actual disc radius (m) - 0.155m
Contact Twiflex for installation details.

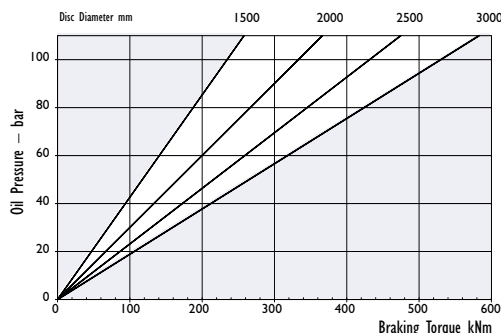
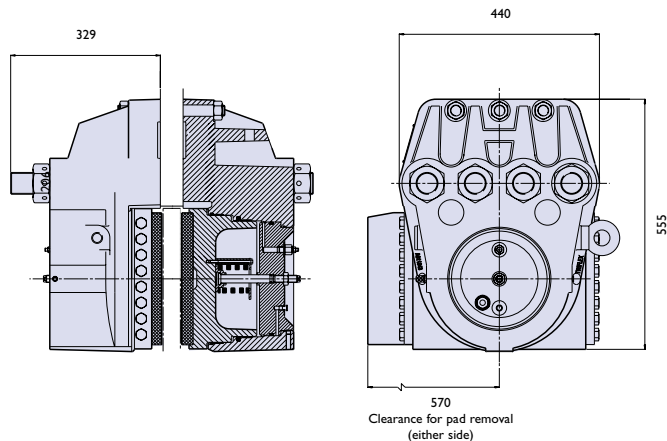

Maximum Pressure 110 bar
Maximum Braking Force = 433kN @ 110 bar
Weight of caliper (2 modules) - 580kg
Volume displacement per 1mm stroke at both pads = 101.5ml

▼ VMS2 and VMS2 SP

Spring applied – Hydraulically released

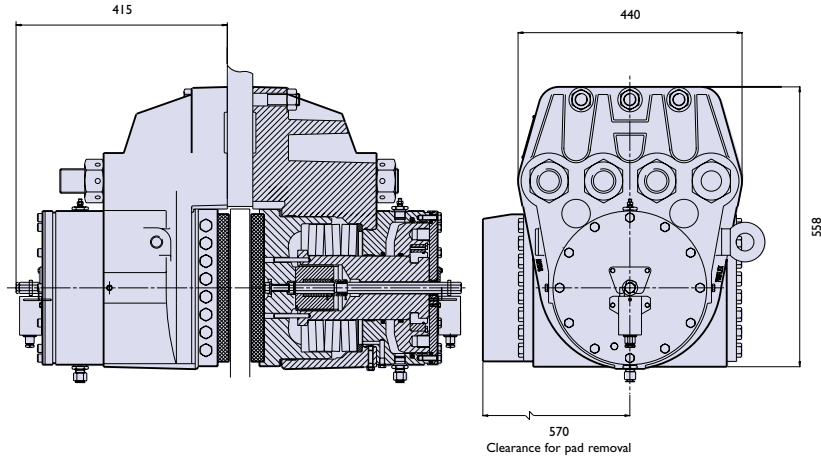
modular
series

The Twiflex VMS2 & VMS2 SP disc brake calipers comprise of two separate modules secured to a centrally located mounting plate by means of rods and bolts and are used with a brake disc thickness of 38mm and over. The central mounting plate thickness is 12mm greater than the brake disc.

Normally one or two brakes will be used per disc, but the number may be increased, depending on disc size. The brake units can be positioned at any angle around the periphery of the disc.

A range of brake discs is available from Twiflex, see Section 3.2.

Minimum disc diameter is 1500mm.

The braking force is widely adjustable by means of shim packs.

The ratings shown on the tables are based on fully bedded and conditioned brake pads with nominal friction coefficient $\mu = 0.4$.

Twiflex Disc Brakes must be used with Twiflex asbestos free brake pads.

Contact Twiflex for installation details.

Note:

Spring fatigue life is a function of the caliper rating.

VMS2

Caliper Type	Disc/Pad Air Gap mm	Braking Force kN	Hydraulic Pressure for Full Retraction bar
VMS392	3	392	210
VMS356	3	356	197
VMS320	3	320	184
VMS283	3	283	167
VMS245	3	245	154
VMS206	3	206	138
VMS167	3	167	122

VMS2 SP

Caliper Type	Disc/Pad Air Gap mm	Braking Force kN	Hydraulic Pressure for Full Retraction bar
VMS2 SP250	3	250	180
VMS2 SP241	3	241	173
VMS2 SP229	3	229	165
VMS2 SP217	3	217	158
VMS2 SP205	3	205	150
VMS2 SP191	3	191	143
VMS2 SP180	3	180	136
VMS2 SP167	3	167	128
VMS2 SP154	3	154.5	121
VMS2 SP142	3	142	113
VMS2 SP129	3	129	106

Weight of Calipers (2 Modules) = 670kg

Volume displacement per 1mm stroke at both pads = 77ml

Braking Torque (kNm) = Braking Force (kN) x Effective Disc Radius (m)

Where Effective Disc Radius (m) = Actual Disc Radius - 0.155m

12.7mm thick brake discs

Nominal diameter mm	A	B	C	D minimum	Inertia kgm ²	Weight kg	Maximum safe disc speed
250	250	128	36	30	0.04	4.0	6500
300	305	166	41	51	0.09	7.3	6000
350	356	210	54	76	0.17	10.9	5100
400	406	260	54	102	0.28	14.1	4400
460	457	311	54	102	0.48	19.1	3900
515	514	368	54	102	0.75	22.7	3500
610	610	464	54	102	1.57	33.0	2900
710	711	565	54	102	3.20	52.3	2500
810	813	660	54	102	6.57	85.5	2200
915	914	762	54	102	10.80	110.9	1900

All dimensions in mm

25.4mm thick brake discs

Nominal diameter mm	A	B	C	D minimum	Inertia kgm ²	Weight kg	Maximum safe disc speed
610	610	343	76	125	2.75	66	2900
760	762	495	76	125	7.0	104	2300
915	914	648	76	230	16.0	150	1900
1065	1067	800	76	230	29.1	220	1600
1220	1219	914	76	230	49.1	273	1400
1370	1372	1067	76	–	80.1	346	1200
1525	1524	1219	76	–	120.5	393	1100
1830	1829	1524	76	–	243.5	522	1000

All dimensions in mm

All Twiflex Brake Discs are bored and drilled to customer requirements. Disc sizes not shown in the Tables can be supplied to order. Brake Discs are manufactured from Spheroidal Graphite Iron.

BRAKE DISCS

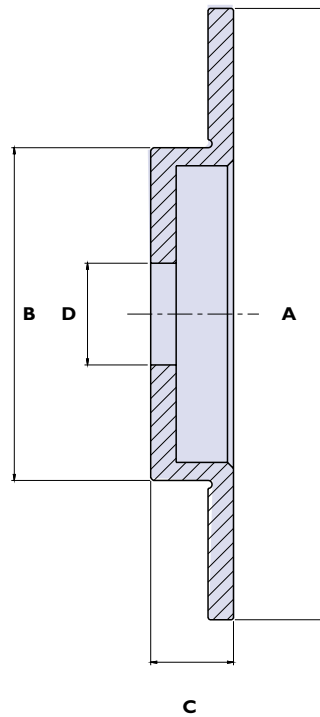

C

HUBS

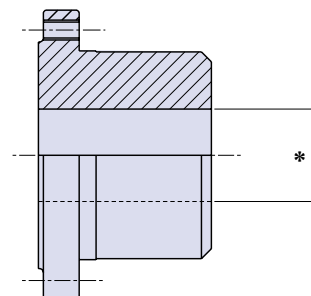

HUBS

* Bores: these can be supplied either parallel or tapered and keywayed to suit customer requirements.

Hubs are manufactured from steel 080M40.



Pneumatic Controllers

Twiflex offer the following types of pneumatic controllers designed for use with Twiflex calipers:

Air Controllers - Types GL & GK

These brake controllers consist of a solenoid valve to switch on or switch off the caliper air supply based on adjustable pressure switches on the input and output lines. The GL control cabinets have a protection rating of IP65 to EN 60.529 and the GK cabinets to IP66.

Optional components available from Twiflex include:

- Pressure regulator to adjust the pressure applied to the caliper
- Manual over-ride valve

The GL controller is suitable for the MU, MS, MR, MX, and GMX range of calipers. A controller, Type 2GL, for operating two similar brakes on separately controlled circuits is available.

The GK controller operates the larger GMR caliper. The GK is also suitable if more than one caliper on the same circuit needs to be controlled.

Both controllers are available in a range of AC and DC voltages and with either normally open or normally closed valves.

Control Cabinet Dimensions

Controller	Width	Height	Depth
GK	380	300	210
GL	240	180	150
2GL	360	180	150

Tension Controllers

A range of Tension Controls are available to suit various applications.

- Paperweb tension control
- Steel unwind control
- Cable reel

These controls vary from simple manual adjustment of pressure to complete close loop control.

Intensifiers

Air Hydraulic Intensifiers can be provided to allow hydraulic brakes to be operated from a low pressure air supply.

Two basic versions are available:

- 20:1 Intensifier
- 13:1 Intensifier

These intensifier assemblies are offered to suit mineral oil and brake fluid hydraulic media.

The following table shows Air hydraulic intensifier assemblies for use with the calipers indicated.



Range of Air hydraulic intensifiers

20:1
22mm Master
cylinder

20:1
31.75mm Master
cylinder

13:1
38mm Master
cylinder

Maximum input air pressure (bar)				7	7	7
Maximum oil displacement (ml)				12.4	50	61
Caliper		Oil volume for full stroke (ml)	Max pressure (bar)	Maximum number of Calipers per intensifier (* indicates full pressure is not achieved)		
Direct acting	T2	2	20	–	–	2 off
	CE2	2	120	6 off	6 off	–
	T20	7	120	1 off	6 off	–
	VC	9	100	1 off	4 off	1 off *
	T40	15	100	–	3 off	3 off *
	VCH	25	135	–	1 off	–
	GMR (H)	40	140	–	1 off	–
Spring applied	MR / MX / GMX (L)	5	50	2 off	9 off	10 off
	MX / GMX (SH)	9	65	1 off	5 off	6 off
	VCS	13	152	–	2 off *	3 off *

FDM Hydraulic Power Unit

This is a combination unit using both air and spring force application to provide a hydraulic output pressure for Twiflex calipers. It is particularly useful for manual control of moving equipment. E.g. locomotives or amusement park rides.

Functions available

	Air		Spring		Hydraulic Output Pressure (bar)
	Service Port	Spring Port	Applied	Retracted	
Functions Operated	●	●		●	67
		●			0
	●		●		138
			●		71



Monitor units

The table below shows the range of monitor units available for the various Twiflex calipers and thrusters.

Note:

- 1 The three function monitoring units indicate:
 - A – Brake on/off (Full retraction achieved)
 - B – Pad wear adjustment
 - C – Pad replacement
- 2 Single function Brake on or off, can also be used to monitor full retraction.
- 3 Many of the three function monitoring units are available as single or dual function units.
- 4 Some monitoring units are available with positive action safety switches and may be supplied as sealed units.
- 5 Proximity switches can be supplied for a number of disc brakes.
- 6 Twiflex also have a range of monitor units that are fully environmentally protected, details available upon request.

Range of Monitor units

		Standard monitor units	Special monitor units	
Caliper/Thruster		Functions available	Functions available	Pos' Action/Sealed
Thruster	K	A		
	L	A		
	XS		A	P,S
	XSH	A		
	S,SD,SH	A,B		
Caliper	MX		C,A	P,S
	GMR		A	S
	TS16	AB		
	VCS	A,B,C	A	P,S
	VKSD	A,B,C	A or B or C	P,S
	VS	A,B,C		
	VMS	A,B,C		

Materials, traceability and finishes

Materials, traceability and finishes

Twiflex Ltd are approved to BS EN ISO 9001:1994, by Lloyds Registry of Quality Assurance. The scope of Twiflex Ltd Quality System embraces all procedures and controls from quotation to delivery of industrial disc brakes.

Materials

All materials are obtained from Twiflex approved suppliers.

Twiflex discs and brake housings, unless otherwise stated, are made from Spheroidal Graphite Iron and actuator housings from cast aluminium.

Traceability

We can offer, at customer's request, component traceability through Lloyds. In special circumstances we can also offer traceability, for example, through the American Bureau of Shipping (ABS), Det. Norske Veritas (DNV), and other recognised authorities.

Finishes

Twiflex can offer a range of finishing processes, depending upon the degree of protection required. Disc brake assemblies requiring full environmental protection are built using stainless steel, hard chrome plating and marine paint.

8

Hydraulic power units



Hydraulic Power Units

Twiflex have consolidated 25 years of development to produce a range of electro-hydraulic power units, which in some form or another will meet most applications. Each power unit has been designed for reliability, high performance and low maintenance, and is supplied with a comprehensive easy to read installation, operation and maintenance manual.

Choosing a suitable hydraulic power pack to operate the selected caliper disc brake may seem at first a daunting task. The Twiflex datasheets contain user guides giving a step-by-step selection process. Twiflex application engineers will be happy to discuss your requirements in detail.

“LC” Electro Hydraulic Power Units

The "LC" range of stand alone power units is designed to operate the Twiflex range MR, MX, GMX, GMR and VCS spring applied hydraulically released brakes, providing a basic brake on/off control. There are various options available including "soft braking", a range of operating and motor voltages, and various add on accessories including a terminal box.

The "soft braking" option is available as an additional slice to facilitate a fast approach soft braking system, which enables the operator to control the rate at which the brake is applied, and incorporates a "fast approach" element to ensure the pads make immediate contact with the disc. Refer to data sheet DS3001.

“MP” Electro Hydraulic Power Units

This "MP" (Modular Range) of Electro Hydraulic Power Units that has been designed to provide an advanced and flexible means of brake control, and to operate in the most arduous conditions. Typically this can be the steel industry where the operating environment is extreme, and the container industry where constant reliable operation all year is expected.

The "MP" unit is essentially an assembly consisting of a base unit, a hydraulic circuit and various auxiliary options. There is a selection from three common base units, the selection, normally made by Twiflex, is determined by the brake to be controlled and the circuit opted for. There are four standard control circuits ranging from a basic on/off control to full closed loop utilising a PLC. The base units can be tailored with various auxiliary options to ensure all specifications are met. The modular system is particularly useful when the installation requires the operation and control of two or more independent brake circuits, or there is a special requirement for meeting a particular industrial specification. Refer to data sheet DS3002.





There are many factors to take into account when determining what type of brake to use on any particular machine. For example, what is the function of the brakes? Are there any external loads? Are there any time delays?

The primary consideration should be to answer the question:

“What do you want the brake to do?”

The application will often fall into one of three main types:

- **Holding Brakes**

In such static applications a suitable factor should always be used to compensate for the possibility of foreign matter contaminating the disc surface, loss of conditioning of the brake pad surface, and to provide an appropriate safety margin, depending on pad material, statutory or other requirements.

- **Dynamic Brakes (and Emergency)**

In a dynamic application the brake must stop all of the moving parts of the machine. Often this function is asked for in conjunction with the holding requirements as an emergency braking function. Basic calculations should, in these cases, include an assessment of operating temperature, power dissipation (to ensure that the pads are maintained in good condition) and expected pad life.

- **Tension Brakes (Continuous Duty)**

This application arises when the brake is called upon to provide a continuous torque or tension on material passing through the machine, for example on tension reels. Special considerations are required to ensure adequate pad life.

Braking calculations are fundamental to good brake selection.

The following calculations are intended as a guide for those wishing to make their own selection. For a more detailed analysis of a proposed braking system, Twiflex Application Engineers can assist in providing details of all expected operating characteristics using a specialist Computer Aided Brake Selection program (CABS).

Defintion of braking terms

Clamping Force (F_n) is the force pressing each brake pad against the disc.

Braking Force (F_b) is the tangential friction force acting between the brake pads and disc.

$$F_b = 2 \cdot \mu \cdot F_n$$

Where: μ is the coefficient of friction between the pad and the disc (a nominal value of 0.4 is assumed by Twiflex).

Braking Torque (T_b) is the moment of braking force about the centre of rotation.

$$T_b = F_b \cdot r_e$$

Where r_e is the effective disc radius.

The calculated braking torques for the range of Twiflex brake calipers are shown in the brochure for a range of standard disc sizes.



Definition of symbols and units

It is important, when making calculations, that a consistent set of units is used.

Symbols and units

ω_m	Maximum disc speed	[rad/sec]
$\dot{\omega}$	Deceleration during braking	[rad/sec ²]
J	Total inertia referred to braked shaft	[kgm ²]
m	External load	[kg]
T _B	Total braking torque	[Nm]
T _L	Load torque (out-of-balance torque)	[Nm]
T _J	Inertia Torque	[Nm]
T _F	Friction torque	[Nm]
t _b	Braking time	[sec]
t _d	Delay time for brake signal	[sec]
t _s	Overall stopping time	[sec]
g	Acceleration due to gravity	[m/sec ²]

Basis of brake calculation

The fundamentals of braking calculations are to ensure that:

- There is sufficient torque to stop and hold the machine at rest
- For dynamic stops, the power dissipation is acceptable for the area of the brake pads being used
- The operating temperature of the brake disc is controlled, to avoid brake fade and reduced performance

The basic data needed to make an initial calculation are any out-of-balance forces acting on the machine, and the total inertia of the moving parts of the machine.

The total braking torque is defined as follows:

$$T_B = T_J + T_L - T_F$$

Effects of friction can be ignored for a conservative estimate of the required braking torque.

It is important, in all cases of dynamic braking, that the inertia of all of the moving parts is referred to the braked shaft when calculating T_J (see below)

Brake calculation

Basic braking calculations are derived from simple mechanics. Both the effects of out of balance loads and the torque needed to stop the inertia in the desired way need to be calculated.

Load torque T_L

Where the machine has any out-of-balance load applied then the effective out-of-balance torque must be calculated.

In the case of a suspended load, for example this is simply given by

$$T_L = m \cdot g \cdot r \quad [\text{Nm}]$$

where r is the radius at which the load acts (based on drum diameter, reel diameter etc.)

The brake will need to overcome this load before it can start to slow down the machine; (it is assumed that the out of balance opposes the action of the brake)

If the load is at rest, the static brake torque will prevent the load from moving. In practice a safety factor should be used in the case where the brake is called upon only to hold this load and is only infrequently used in a dynamic manner. In these cases a service factor of 2 is recommended to allow for external environmental conditions, i.e. the brake should be rated to give twice this calculated value.



With some types of machine such as downhill conveyors or escalators a component of the load acts in the direction of motion. In these cases the above equation should be modified as follows:

$$T_L = m \cdot g \cdot r \cdot \sin \theta \quad [\text{Nm}]$$

Where θ is the angle of the motion to the horizontal.

In cases where the load does not produce a direct torque on the braked shaft (e.g. there is a gearbox between the loaded shaft and the brake) the load torque should be modified accordingly.

In cases of dynamic braking where the load torque is not constant, for example on wind turbines where the aerodynamic load varies with the speed of the machine, then the equation for T_L becomes complex and the selection should be referred to Twiflex.

Inertia torque T_J (dynamic braking only)

Having overcome the external forces additional braking torque is required to stop all the moving parts of the machine. This additional torque is calculated as follows:

$$T_J = J \cdot \dot{\omega} \quad [\text{Nm}]$$

In this equation the deceleration required can readily be calculated from the braking time.

$$\dot{\omega} = \omega / t_b$$

In some special cases (see 4.4.3 below) more precise calculation of speed and time may be required.

The moment of inertia of the system (J) should represent all moving parts.

For example, in a hoist calculation should be made to include the motor, brake disc, gearbox, winding drum, ropes, load etc. again with a suitable allowance for any mechanical advantage at various parts of the system.

The effective inertia of the load is given simply as:

$$J = m \cdot r^2 \quad [\text{kgm}^2]$$

For the winding drum the following well established formula can be used for an initial estimate (can also be used for flat discs):

$$J = \pi \rho l (D^4 - d^4) / 32 \quad [\text{kgm}^2]$$

Where l is the length of the drum,

D is the outside diameter

d is the inside diameter

and ρ is the density of the material (7840 kg/m³ for steel)

The inertia of the motor should also be included in the calculations. These values can be estimated but should be obtained directly from the motor manufacturer.

NOTE All inertia must be referred to the brake shaft.

For example, if the brake is positioned on the low speed shaft of a machine (gearbox output shaft) then all calculated inertia values (motor, couplings etc) must be referred to this shaft.

When referring inertia J_B from one shaft with speed ω_B to another shaft with speed ω_A use:

$$J_A = J_B (\omega_B / \omega_A)^2$$

Special requirements

In certain special cases there are other direct considerations to be applied when making braking calculations.

In mine hoists the service factor for holding is defined, as are allowable levels of deceleration, especially when manriding.

For escalators allowable stopping distances are defined by standards in Europe, whilst in the USA levels of deceleration are also included in standards.

Twiflex are able to offer assistance with calculations in such special cases.

Other considerations

To optimise braking performance there are other considerations which must be taken into account.

Rubbing speed

In the special case of high-speed machinery a further consideration is the speed at which the disc is travelling through the pads when the brake operates. It is the linear speed of the disc that is important and this is usually measured at the effective radius.

Thus the rubbing speed is given as:

$$\text{Rubbing speed} = \omega_m \cdot r_e \quad (\text{m/s})$$

In general a maximum speed of 30m/s is recommended for standard brake pad materials. Above this value it is likely that the effective coefficient of friction will be reduced leading to a reduction in braking performance. For certain applications where the rubbing speed is particularly high (up to 100m/s) special pads are available manufactured from sintered materials.

Refer to Twiflex for details.

Operating temperatures

During a dynamic application of a brake the energy of the machine will be converted to heat, generated between the pad and the disc. It is the temperature of the disc surface that is normally used to assess the brake performance. Failure to take account of the peak temperature can lead to a reduced braking performance due to the onset of brake fade.

With standard brake pads a peak temperature of 250°C has been found to be acceptable, although in certain cases higher temperatures might be permitted. In the case where sintered pads are used peak temperatures in excess of 600°C are possible.

The operating temperature also determines pad wear. The higher the temperature, the greater the wear rate of the pads.

These calculations require a detailed analysis such as that carried out by the Application Engineers at Twiflex using CABS and other specialist software.

Power dissipation

In order to provide a consistent controlled performance of a brake it is also important to check the power dissipated during a stop. This affects the condition of the brake pads.

To calculate the power dissipation it is necessary to calculate the total energy absorbed during the stop, estimated as follows:

$$\text{Kinetic energy (KE)} = J \cdot \omega_m^2 / 2 \quad (\text{Joules})$$

In the case of external loads further allowance should also be made for the change in potential energy of the system. For example in the case of a hoist this is determined by how far the load drops during the braking cycle.

The mean power dissipated is therefore given by:

$$\text{Mean power dissipation} = \text{KE} / t_b \quad (\text{Watts})$$

This is usually converted to what is termed the Mean Specific Power Dissipation (kW/cm²) for evaluation of pad performance, i.e. the mean power dissipation is divided by the pad area.

A value of 0.7kW/cm² has been shown to be acceptable for emergency stops of around 10 seconds duration, providing that the pads have been well bedded and conditioned. Higher values can be used for shorter stopping times.

In the special case of tensioning duties the value of the mean specific power dissipation is more typically around 0.06 kW/cm².

Failure to observe this basic selection criteria may result in poor braking performance and low pad life. Twiflex Application Engineers will be only too happy to assist in the selection process to meet your application requirements.



Application Form



To: Twiflex Technical Sales Department	From:
Fax: +44 (0) 20 8 894 6056	Pages:
Phone: +44 (0) 20 8 894 1161	Date:
Re: Technical Sales Enquiry	CC:

Urgent For Review Please Comment Please Reply Please Recycle

Sales Enquiry - Prompt Reply Please

My Name:

Name of Company or Organisation:

Address:

Telephone:

Facsimile:

Email:

Description of Application:

Type of Braking Required (e.g. Holding, Dynamic Stopping, Emergency Stopping, Tensioning):

Service Brake (Between Motor and Gearbox):

Motor Rating:

Safety Braking Required?

Brake Torque:

Comments :

TWIFLEX LIMITED

104 The Green, Twickenham, Middlesex. TW2 5AQ England

CUSTOMER ENQUIRIES: 020 8893 9622 ● Switchboard: 020 8894 1161 ● Facsimile: 020 8894 6056

Website: www.twiflex.co.uk ● E-mail: sales@twiflex.co.uk

ADVANCED BRAKING TECHNOLOGY



TWIFLEX LIMITED

104 The Green, Twickenham, Middlesex. TW2 5AQ England

CUSTOMER

ENQUIRIES: 020 8893 9622

Switchboard: 020 8894 1161

Facsimile: 020 8894 6056

Website: www.twiflex.co.uk

E-mail: sales@twiflex.co.uk